

RECLAMATION

Managing Water in the West

Technical Memorandum No. MERL-2012-40

Guidelines for Field Installation of Corrosion Monitoring and Cathodic Protection Systems



Mission Statements

The U.S. Department of the Interior protects America's natural resources and heritage, honors our cultures and tribal communities, and supplies the energy to power our future.

The mission of the Bureau of Reclamation is to manage, develop, and protect water and related resources in an environmentally and economically sound manner in the interest of the American public.

Technical Memorandum No. MERL-2012-40

Guidelines for Field Installation of Corrosion Monitoring and Cathodic Protection Systems



BUREAU OF RECLAMATION
Technical Service Center, Denver, Colorado
Materials Engineering and Research Lab Group, 86-68180

Technical Memorandum No. MERL-2012-40

**Guidelines for Field Installation of Corrosion
Monitoring and Cathodic Protection Systems**

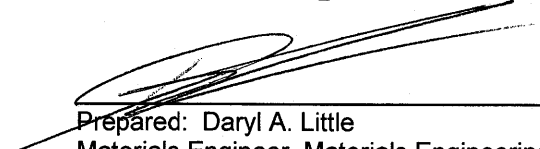
Prepared: Daryl A. Little
Materials Engineer, Materials Engineering and Research Lab Group, 86-68180

11/29/12
Date

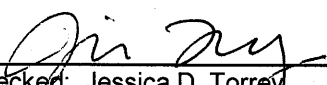
Checked: Jessica D. Torrey
Materials Engineer, Materials Engineering and Research Lab Group, 86-68180

11/29/12
Date

Editorial Approval: Teri Manross
Technical Writer-Editor, Client Support and Technical Presentations Office, 86-68010

12/12/12
Date

Technical Approval: Lee E. Sears
Materials Engineer, Materials Engineering and Research Lab Group, 86-68180

12/13/12
Date

Peer Review: William F. Kepler, P.E.
Civil Engineer, Materials Engineering and Research Lab Group, 86-68180

11/29/2012
Date

REVISIONS					
Date	Description	Prepared	Checked	Technical Approval	Peer Review

Contents

	<i>Page</i>
Chapter I: Introduction.....	1
Corrosion Monitoring and Cathodic Protection Systems	1
Terminology.....	1
Role of Contracting Officer's Representative.....	3
Reference Standards.....	3
ASTM International	3
Bureau of Reclamation	3
National Electrical Manufacturer's Association.....	4
Chapter II: Components	5
Common System Components.....	5
Cable	5
Metallurgical Welds and Bitumastic Material	6
Test Stations.....	7
Anode Junction Boxes	8
Shunts.....	8
Variable Resistors	9
Protective Barriers	10
Permanent Reference Electrodes	10
Insulated Joint Flange Kit.....	12
Casing Isolation Devices.....	14
Dielectric Barrier Material.....	15
Warning Tape.....	15
Sand.....	16
Conduit.....	16
Galvanic Anode Systems	16
Anodes	16
Buried.....	16
Submerged	17
Impressed Current Systems.....	18
Anodes	18
Buried.....	18
Submerged	19
Rectifiers	20
Pea Gravel.....	21
Vent Pipe.....	21
Carbonaceous Backfill	22
Anode Centralizing Devices	24
Grounding Rod and Cable	24
Rectifier Protective Barriers	24

Contents (continued)

	<i>Page</i>
Chapter III: Installation.....	25
General Installation.....	25
Cable.....	25
Inspection for Quality Control.....	25
Exothermic Metallurgical Bonds.....	25
Electrical Continuity Joint (Jumper) Bonds.....	27
Structure Cables.....	29
Buried Applications.....	29
Cable Identification.....	30
Electrical Isolation (Insulation).....	31
General.....	31
Isolation Joint Flange Kit.....	31
Installation.....	31
Testing.....	33
Casing Isolation.....	34
Installation.....	34
Testing.....	36
Test Stations and Junction Boxes.....	36
Locations.....	36
Corrosion Monitoring.....	37
Isolation Joints.....	39
Casings.....	41
Foreign Line Crossings.....	44
Galvanic Anode(s).....	46
Barriers.....	50
Triangular Barriers.....	50
Rectangular Barriers.....	50
Galvanic Anode Systems.....	53
Buried Anodes.....	53
Submerged Anodes.....	53
General.....	53
Suspended.....	53
Surface Mounted.....	57
Impressed Current Systems.....	58
Rectifiers.....	58
Anode Junction Boxes.....	58
Buried.....	59
Shallow Bed.....	59
Deepwell Bed.....	60
Submerged.....	64
Wire Anodes.....	64
Flush Mounted.....	66

Contents (continued)

	<i>Page</i>
Permanent Reference Electrodes	68
Buried.....	68
Submerged	69
Through-wall.....	69
Surface Mounted.....	70
Chapter 4: Startup and Testing.....	71
Procedures.....	71
Safety	71
Test Equipment.....	72
Testing.....	74
Pre-energizing	74
Energizing and Testing Systems.....	75
First Test Cycle.....	75
Second and Subsequent Testing Cycles.....	76
Appendix: Galvanic CP System Checklist and Impressed Current CP System Checklist	

Figures

	<i>Page</i>
1 Stranded copper cable with HMWPE insulation (left) and a combination of HMWPE and Halar insulation (right) for chloride environments.....	6
2 Metallurgical weld and bitumastic materials for attaching cables to structure.....	7
3 Big Fink type test station showing the components: (a) cap, test board, and PVC post; and (b) and (c) completed test stations.....	7
4 Anode junction boxes with individual shunts and variable resistors.....	8
5 Rectifier shunt for determining current output. Shunt has a rating of 50 amperes/50 millivolts.	9
6 Various types of available anode shunts: (a) Cott shunts are color coded for rating, with ratings of 0.1 ohm (red), 0.01 ohm (yellow), and 0.001 ohm (orange).....	9
7 Variable resistors for controlling galvanic and impressed current anode output: (a) slide resistor, and (b) and (c) dial type resistors.	10
8 (a) Buried copper/copper sulfate, permanent reference electrode schematic, and (b) finished product.....	12
9 (a) Through-wall, and (b) wall attached submerged permanent reference electrodes	12

Figures (continued)

	<i>Page</i>
10	Schematic of type E isolation flange kit, showing the various components for two-sided isolation13
11	Schematic of type F isolation flange kit, showing the various components for single-sided isolation14
12	Casing isolation kit for metallic pipelines15
13	Warning tape used for marking location of CP cables15
14	Conduit for mounting submerged anodes such as rod and wire anodes16
15	Bare and bagged galvanic anodes17
16	Galvanic anodes for use on submerged structures18
17	(a) Graphite impressed current anode, and (b) HSCI impressed current anode.....19
18	Linear anode of conductive-polymer coated copper, surrounded by high conductivity coke breeze, and held in place by a porous, woven, acid-resistant jacket.19
19	Examples of impressed current anodes include: (a) disk, (b) wire, pencil, and mesh; (c) stick or rod; and (d) through-wall probe electrodes20
20	Rectifiers used for impressed current CP systems, showing: (a) galvanized enclosure, and (b) manual taps for adjusting the voltage.....21
21	(a) Vent pipe with vertical and transverse slots for deep well anode beds, and (b) circled area blown up to show vertical slot cut in the pipe.....22
22	(a) Bag of petroleum coke backfill used for impressed current anode beds, and (b) spherical grained petroleum coke structure23
23	Example of device for centering anodes in deep well anode beds24
24	Schematic diagrams show the proper procedure for metallurgically bonding cables to metallic structures.....26
25	Schematic shows jumper bond installation for: (a) a flanged joint (nonisolating), (b) a push-on joint, and (c) a flexible coupling (multiple component coupling).....28
26	Schematic shows jumper bond installation for Victaulic joints.....28
27	Schematic shows jumper bond installation for PVC to steel fitting.28
28	Examples of jumper bonds for various pipe situations: (a) The mortar coating was removed at the joint to attach the jumper bond; (b) jumpers were installed on the pipe across the various joints, and the weld nuggets were covered with bitumastic molded cap (Handy Cap) prior to burial; and (c) bonds were installed across the expansion joint on an outlet works pipe, and the weld nuggets were coated with a bitumastic coating.29

Figures (continued)

	<i>Page</i>
29	Schematic for installation of buried cables30
30	Installation of warning tape in a cable trench.30
31	Schematic for identifying and labeling all cables terminating in test stations, junction boxes, and rectifiers.31
32	Schematic shows isolation bolt installation for isolation flange kit.32
33	Schematic shows bolt tightening sequence to provide even sealing pressure on a flange gasket.32
34	Test instruments for ensuring proper installation and operation of isolation (insulation) joints flange kits: (a) Model 601 is for testing aboveground joints, and (b) Model 702 is for testing joints underground34
35	(a) Casing installation, including spacers and end seals; and (b) casing isolators installed on a coated steel pipe35
36	Drawing of test station installation for corrosion monitoring: (a) plan view of test station, and (b) close-up view of the test board38
37	Drawing of test station installation for isolation joint: (a) plan view of test station, and (b) close-up view of the test board40
38	Drawing of test station installation for a casing: (a) plan view of test station, and (b) close-up view of the test board42
39	Drawing of test station installation for a casing with galvanic anode: (a) plan view of test station, and (b) close-up view of the test board43
40	Drawing of test station installation for a foreign line crossing: (a) plan view of test station, and (b) close-up view of the test board45
41	Drawing of test station installation for a single galvanic anode: (a) plan view of test station, and (b) close-up view of the test board47
42	Drawing of test station installation for multiple galvanic anodes: (a) plan view of test station, and (b) close-up view of the test board48
43	Drawing of junction box installation for multiple galvanic anodes: (a) plan view of junction box, and (b) close-up view of the anode panel49
44	Triangular test station design for protecting test stations and junction boxes from damage51
45	Rectangular barriers for safety and preventing damage to rectifiers outside of plant yards52
46	Example schematic of horizontally installed galvanic anodes in a ground tank: (a) elevation view, and (b) plan view55
47	Example schematic of vertically installed galvanic anodes in a ground tank: (a) elevation view, and (b) plan view56

Figures (continued)

	<i>Page</i>
48	Steel anchor for supporting ropes attached to suspended galvanic anodes such as found in a storage tank57
49	Anode junction boxes for impressed current CP systems: (a) installation with shunts only, and (b) installation with shunts and variable resistors59
50	Installed impressed current system showing rectifier, anode junction box, external circuit breaker switch, and vent pipe62
51	Schematic of example deep well anode bed installation63
52	(a) Example of an anode centralizer for deep well anodes, and (b) with anode and vent pipe attached for installation64
53	(a) Slotted pipe mounted on sump wall for wire anode installation, and (b) close-up of the slots in the pipe and the wall attachment details.....65
54	Schematic of flush-mounted, disk mixed metal oxide anode showing front view (left side) and profile assembly67
55	Flush mounted impressed current disk anodes: (a) arrow indicates the location of a disk anode on the upstream side of a radial gate; (b) downstream side of the gate showing the finished anode installation68
56	Multimeters for measuring potentials associated with CP systems: (a) Fluke 27 digital multimeter, and (b) MC Miller LC-4 variable resistance input digital multimeter73
57	Copper/copper sulfate portable reference electrode for determining structure-to-electrolyte and anode-to-electrolyte potentials73
58	Meter for determining resistivity of soil around anodes.....74

Tables

	<i>Page</i>
1	Physiological effects of 60-hertz AC72

Chapter I

Introduction

Corrosion Monitoring and Cathodic Protection Systems

Corrosion monitoring systems facilitate testing to determine if corrosion is progressing and to determine the level of cathodic protection (CP) being provided by a cathodic protection system. The system requires electrical continuity of the structure and between the structure and test stations to determine structure-to-electrolyte potentials.

Cathodic protection is a means of reducing corrosion of a metal by artificially causing direct current to flow from external anodes, through the electrolyte (soil or water), and onto the structure to be protected. The two types of CP systems are galvanic anode and impressed current.

Galvanic anode CP systems provide cathodic current by galvanic corrosion or by sacrificing one material to prevent corrosion of the other. This type of system is often referred to as a sacrificial anode CP system. Both the structure and the anode must be in contact with the electrolyte.

Impressed current type CP systems provide cathodic current from an external power source. A direct current (DC) power source forces current to discharge from anodes, through the electrolyte, and onto the structure to be protected.

Terminology

Bonded dielectric coating: A protective barrier coating system with high electrical resistivity bonded directly to the underlying metal and, for the most part, physically and electrically isolating the metal from the electrolyte.

Current interrupter: A device used to automatically switch the current on and off at set intervals. Used to measure the polarized or “instant off” potential.

Electrolyte: An electrically conductive solution, such as soil or water. The terms for these specific conductive solutions may be substituted for the word “electrolyte” in these definitions.

Foreign structure: Any metallic structure that is not intended to be in electrical contact with the structure requiring corrosion monitoring and/or CP.

Joint bonds: Cables metallurgically bonded to pipe to ensure electrical continuity for CP.

Junction box: An enclosure containing the terminals from multiple anodes and/or structures along with accessories such as calibrated shunts and variable resistors. From the junction box, a single cable is normally fed to the structure or rectifier.

Polarization: The difference between polarized and native potentials.

Portable voltmeter: Any portable instrument for measuring voltage drops across electrical components or potential (voltage) differences between a structure and a stable reference electrode:

- Should have a minimum input impedance of 10 megohm.
- Should be capable of measuring DC voltages between ± 0.1 millivolts and ± 100 volts.

Rectifier: An electrical device that converts an alternating current (AC) input to a DC output. The rectifier typically includes a stepdown transformer section to reduce the incoming AC voltage, as well as a rectification section that converts current to DC, along with meters, fuses, lightning arresters, and other accessories.

Reference electrode: An electrode whose open circuit potential is constant under similar conditions of measurement, which is used for measuring the relative potentials of other electrodes (e.g., protected structures). A copper/copper sulfate reference electrode is often used for such a purpose.

Shunt: Calibrated resistor placed within a circuit to determine the current flow within the circuit. A shunt has a known, fixed resistance, and its calibration is expressed in ohms or amperage/voltage.

Stray current interference: Corrosion resulting from current through paths other than the intended circuit; i.e., corrosion occurring on a protected structure caused by the CP system on a foreign structure, or some other source of current.

Structure: The pipe, gate, trashrack, tank, or other metalwork being monitored or cathodically protected.

Structure-to-electrolyte potential: The potential, or voltage difference, developed by a structure in an electrolyte when compared with a stable reference electrode. Also referred to as structure-to-soil and structure-to-water potentials.

Static structure-to-electrolyte potential: The structure-to-electrolyte potential determined without any external current (e.g., prior to energizing a CP system and lacking interference or other currents) or after such a current source has been disconnected for an extended time period. Also referred to as native structure-to-electrolyte potential.

Uncorrected structure-to-electrolyte potential: The structure-to-electrolyte potential determined with the CP system energized and CP current flowing. This potential is also sometimes called a protective potential.

Polarized structure-to-electrolyte potential: The structure-to-electrolyte potential determined after the CP system has been energized for a sufficient amount of time, but immediately after it has been interrupted. Also referred to as “instant off” structure-to-electrolyte potential.

Test station: A location for conducting tests on a protected structure, having an enclosure containing terminals of cables from the structure and from any galvanic anodes along with accessories such as calibrated shunts and variable resistors.

Role of Contracting Officer’s Representative

The major role of the Contracting Officer’s Representative (COR) inspector is to periodically observe the contractor installation of the corrosion monitoring and CP systems. This will ensure that the system is being installed according to the specification sections, that the material components installed meet specification requirements and are approved, and that proper safety practices are adhered to at all times. In addition, the COR inspector has the authority to change the proposed locations of test stations, junction boxes, cable runs, rectifiers, and anode beds based on field issues such as safety, probable damage, agricultural field locations, etc. Technical Service Center corrosion personnel should be informed of all significant proposed anode bed location changes prior to installation to determine if it will adversely affect the operation of the CP system.

Reference Standards

ASTM International

ASTM B 418-12	Cast and Wrought Galvanic Zinc Anodes
ASTM B 843-07	Magnesium Alloy Anodes for Cathodic Protection
ASTM C 33/C33 M-11a	Concrete Aggregates

Bureau of Reclamation

USBR M-47	Standard Specification for Repair of Concrete
-----------	---

National Electrical Manufacturer's Association

NEMA 250-2008

Enclosures for Electrical Equipment (1000 Volts
Maximum)

Chapter II

Components

Common System Components

Cable

1. Single-conductor: Stranded, plain, annealed copper cable.
2. Cable insulation:
 - a. Rated for 600 volts and direct burial or immersion.
 - b. High molecular weight polyethylene (HMWPE) outer jacket with minimum thickness of 0.100 inch (figure 1).
 - c. Dual insulation construction, inner layer of Halar or Kynar, and outer layer of HMWPE for impressed current anode cables in chloride environments (figure 1).
3. Unspliced lengths to permit installation from terminus to terminus (e.g., anode to junction box) free of splices and without stress.
4. Cable sizes and insulation color:¹
 - a. No. 6 American Wire Gauge (AWG) or larger for joint bond cables (black insulation).
 - b. No. 6 AWG or larger for structure to rectifier cables (black insulation).
 - c. No. 6 AWG or larger for structure or bond cables in test stations (black insulation).
 - d. No. 12 AWG or larger for test cables in test stations (black insulation).
 - e. No. 10 AWG or larger for impressed current anodes (red insulation if available).
 - f. No. 12 AWG or larger for galvanic anodes (red insulation if available).
 - g. No. 14 AWG for permanent reference electrodes (yellow insulation).
 - h. Foreign structure cables (blue or white insulation if available).

¹ For specific projects, refer to the cable section in corrosion monitoring and cathodic protection specification, section 26 42 1X.

- i. Casing cables (orange insulation if available).
- j. No. 4 AWG or larger bare cable for grounding system.

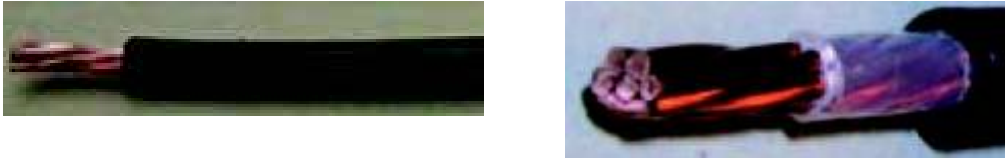

Figure 1. Stranded copper cable with HMWPE insulation (left) and a combination of HMWPE and Halar insulation (right) for chloride environments. (Impressed Current Cathodic Protection Datasheets 2.6.6 and 2.6.7 courtesy of Cathodic Protection Co. Ltd.)

Metallurgical Welds and Bitumastic Material

Metallurgical welds: Exothermic metallurgical bond system by ThermOweld, 4102 South 74th East Avenue, Tulsa, OK 74145-4700; or equal, having the following essential characteristics:

1. Specifically designed for CP systems.
2. Specifically designed for metallic substrate materials.
3. Uses a special alloy to provide minimum heat effect on the substrate material.
4. Current carrying capacity equal or better than that of the conductor.

Bitumastic material: Royston Handy Cap, manufactured by Royston Laboratories, Inc., 128 First Street, Pittsburgh, PA 15238; or equal, having the following essential characteristics:

1. Specifically designed for CP systems.
2. Applied with primer coat as needed.
3. Approved dielectric coating material.
4. Suitable for the intended environment.

Figure 2 shows an example of metallurgical weld and bitumastic materials.



Figure 2. Metallurgical weld and bitumastic materials for attaching cables to structure. (ThermOweld products courtesy of Protection Engineering)

Test Stations

Test station: Big Fink (Figure 3), manufactured by Cott Manufacturing Company, 1944 Gardena Avenue, Glendale, CA 91204; or equal, having the following essential characteristics:

1. Above-ground, orange capped, post-mounted type unless otherwise specified.
2. Post is 7-foot-long, 3-inch-diameter, polyvinyl chloride (PVC) with a ½-inch-diameter, solid PVC cross bar unless otherwise specified.
3. Specifically constructed for CP system installations.
4. Sufficient number of terminals (five terminals minimum) with associated hardware for the number and size of cables.

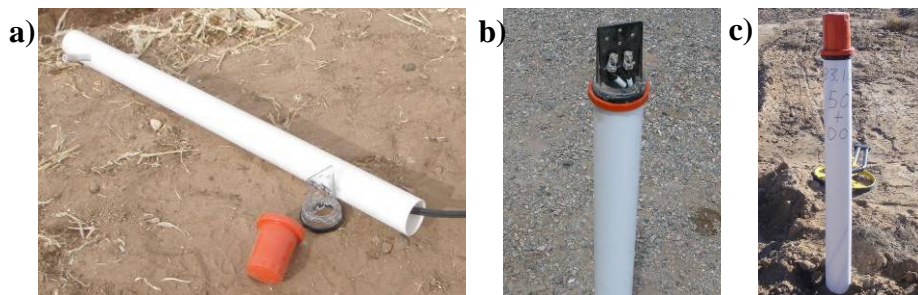

Figure 3. Big Fink type test station showing the components: (a) cap, test board, and PVC post; and (b) and (c) completed test stations.

Anode Junction Boxes

Anode junction boxes are required for locations with too many galvanic anodes to install in a test station and for impressed current CP systems (Figure 4). Anode junction boxes have the following essential characteristics:

1. Enclosed within a National Electrical Manufacturer's Association (NEMA) 250, Type 3-R, lockable cabinet constructed of No. 16 gauge or thicker galvanized steel or fiberglass that is weatherproof, lockable, and vented for heat dissipation.
2. Specifically constructed for CP system installations.
3. Sufficient number of terminals (five terminals minimum) with associated hardware for the number and size of cables.
4. Equipped with 0.01 ohm calibrated shunt for each anode.
5. Equipped with variable resistors of adequate electrical rating for each anode.
6. Engraved 1/4-inch minimum NEMA grade C phenolic panel.
7. Solderless, pressure-type terminals.
8. Identified terminals.
9. Equipped with combination bracket for pole or wall mounting.

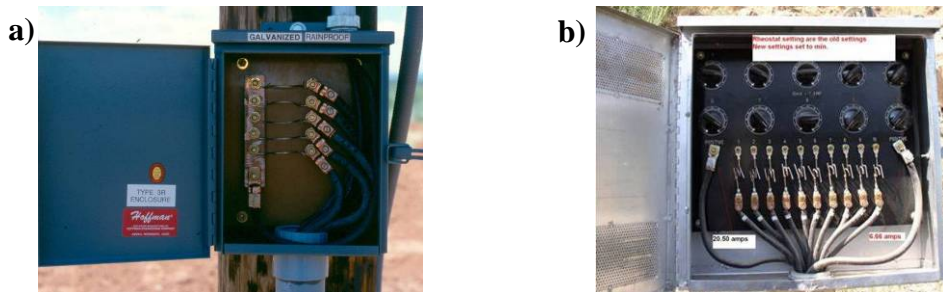

Figure 4. Anode junction boxes with individual shunts and variable resistors.

Shunts

Shunts are used for determining the current output of the rectifier and anodes. They come in a few different styles and are rated as amperes (A) per voltage (Figure 5) and resistance (Figure 6).



Figure 5. Rectifier shunt for determining current output. Shunt has a rating of 50 amperes/50 millivolts.

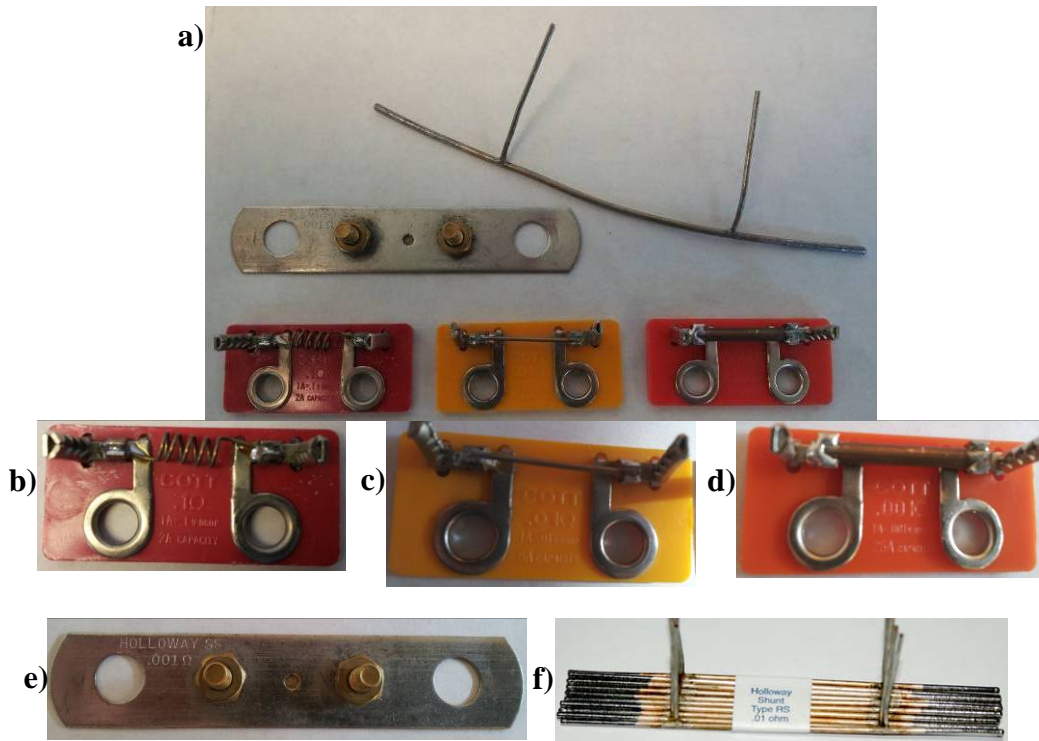

Figure 6. Various types of available anode shunts: (a) Cott shunts are color coded for rating, with ratings of 0.1 ohm (red), 0.01 ohm (yellow), and 0.001 ohm (orange). The same shunts are shown enlarged in (b), (c), and (d), respectively. Holloway type shunts are shown in e) and f), with ratings of 0.001 ohm and 0.01 ohm, respectively.

Variable Resistors

Variable resistors are used for adjusting the output of the anodes to prevent overpolarization, extend anode life, and balance anode output at location with multiple anodes. Two main types of variable resistors are available: slide resistors (Figure 7a) and dial resistors (Figure 7b and c).

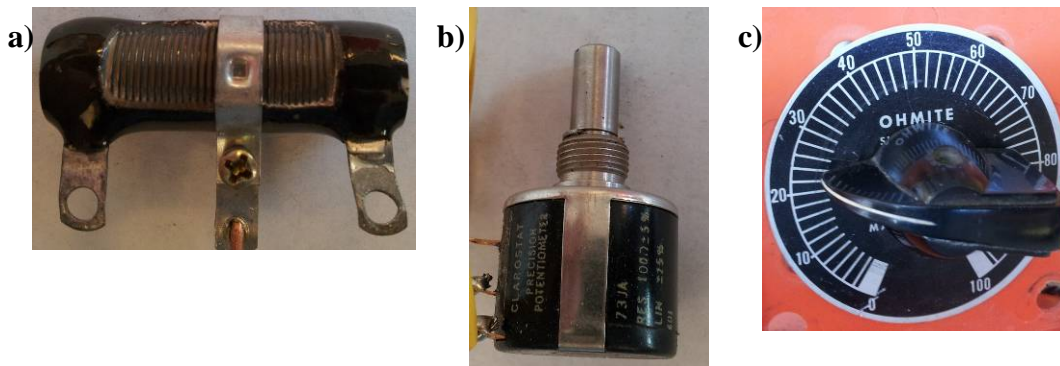

Figure 7. Variable resistors for controlling galvanic and impressed current anode output: (a) slide resistor, and (b) and (c) dial type resistors.

Protective Barriers

1. Triangular barriers for test stations and junction boxes:
 - a. Welded structure consisting of:
 - i. Three 7-foot-long, 2.5- to 3-inch-diameter steel pipes.
 - ii. Three 3-foot-long, 2-inch-diameter steel pipes.
 - iii. Concrete for filling riser pipes and footers.

Permanent Reference Electrodes

Permanent reference electrodes used for CP systems are typically copper/copper sulfate, silver/silver chloride, and zinc. Figure 8 shows a schematic of a buried reference electrode, and Figure 9 shows the through-wall and wall mounted or hanging electrodes. These reference electrodes have the following essential characteristics:

1. Material and type dependent on environment; refer to project specification.
2. No. 14 AWG stranded copper cable with yellow HMWPE insulation.
3. Minimum 20-year design life.
4. ± 5 millivolts (mV) with 3.0-microamp load.
5. Optional antifreeze protection.
6. Buried:
 - a. Double membrane, ceramic cell in a geomembrane package with specialized backfill to retain moisture.

7. Through-wall:
 - a. Type:
 - i. Saturated, gelled, silver/silver chloride through-wall permanent reference electrode for use in brackish water: model AG-6-TH, manufactured by GMC Corrosion & Electrical, Inc., 2132 Grove Avenue, Suite F, Ontario CA, 91761; or equal.
 - ii. Saturated, gelled, copper/copper sulfate through-wall permanent reference electrode for use in fresh water: model CUG, manufactured by Electrochemical Devices, Inc., PO Box 31, Albion RI, 02802; or equal.
 - iii. Zinc through-wall permanent reference electrode for use in fresh water: model ZIN, manufactured by Electrochemical Devices, Inc., PO Box 31, Albion RI, 02802; or equal.
 - b. Designed for ½-inch to 1-inch Iron Pipe Size or National Pipe Taper tapped holes.
 - c. Can be readily removed and reinstalled from exterior of structure.
8. Submerged wall mounted or hanging:
 - a. Type:
 - i. Saturated, gelled, silver/silver chloride, regular immersion, permanent reference electrode for use in brackish water: model AGG, manufactured by GMC Corrosion & Electrical, Inc., 2132 Grove Avenue, Suite F, Ontario CA, 91761; or equal.
 - ii. Saturated, gelled, copper/copper sulfate, through-wall permanent reference electrode for use in fresh water: model CUG, manufactured by Electrochemical Devices, Inc., PO Box 31, Albion RI, 02802; or equal.
 - b. Rugged 1-inch plastic housing.
 - c. Optional magnetic mount for easy attachment to steel structure.

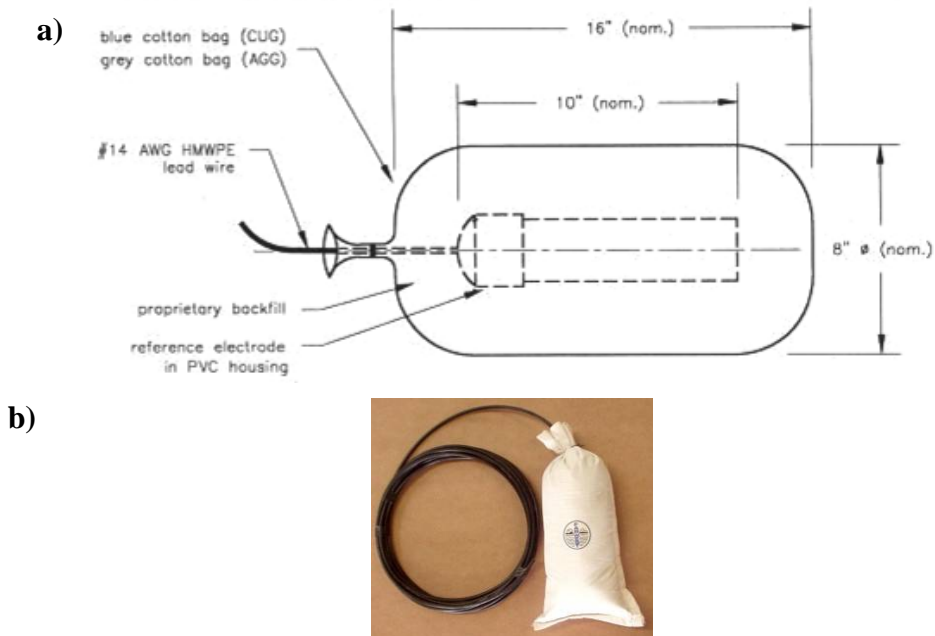

Figure 8. (a) Buried copper/copper sulfate, permanent reference electrode schematic, and (b) finished product. (Courtesy of Farwest Corrosion Control Company)



Figure 9. (a) Through-wall, and (b) wall attached submerged permanent reference electrodes. (Courtesy of Farwest Corrosion Control Company)

Insulated Joint Flange Kit

Flange insulating kits should consist of a type "D" (ring type joint flanges), type "E" (full-face, shown in Figure 10), or type "F" (raised face joint flange, shown in Figure 11) insulating gasket (1/8-inch-thick minimum) with the following essential characteristics:

1. Full-length insulating flange bolt sleeves for the appropriate bolt size. One insulating sleeve for each bolt, two insulating washers, and two steel washers. A one-piece insulating sleeve and washer can be substituted for the separate sleeve and two insulating washers.

2. The gasket material should be constructed of an approved material, typically glass reinforced epoxy, mylar, nitrile, phenolic, or polyethylene.
3. Suitable for appropriate pipeline operating pressures.
4. Coating for buried insulated pipe flanges:
 - a. The wax-tape coating should conform to the requirements of American Water Works Association (AWWA) C217 and consist of three parts: surface primer, wax tape, and outer covering.
 - b. Primer should be a blend of petrolatum, plasticizer, and corrosion inhibitors.
 - c. Plastic-fiber felt tape, 50 to 70 mils thick, and saturated with a blend of petrolatum, plasticizer, and corrosion inhibitors.
 - d. Outer covering should be a plastic wrapper consisting of three each: 50 gauge, clear polyvinylidene chloride, high cling membranes wound together as a single sheet.

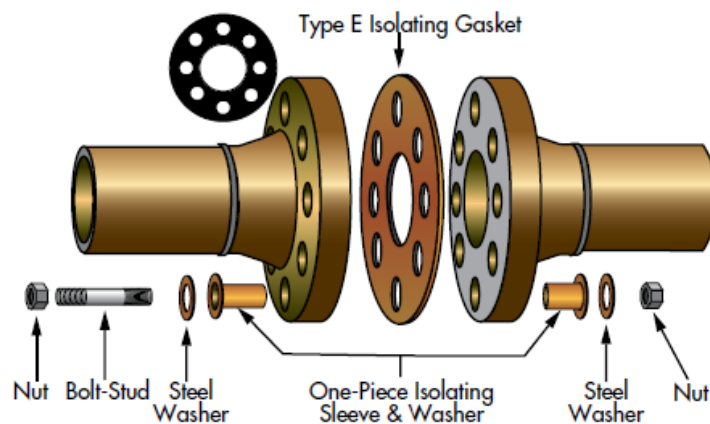

Figure 10. Schematic of type E isolation flange kit, showing the various components for two-sided isolation. (Courtesy of Advanced Products & Systems)

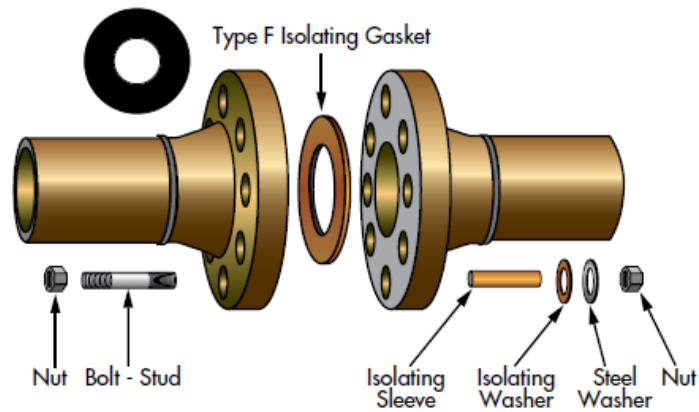

Figure 11. Schematic of type F isolation flange kit, showing the various components for single-sided isolation. (Courtesy of Advanced Products & Systems)

Casing Isolation Devices

1. Sleeve:

a. Materials:

- i. Mild steel (Figure 12a)
- ii. Stainless steel
- iii. Injection molded, high-density, virgin polyethylene (Figure 12b)
- iv. Ultraviolet resistant polypropylene

b. Coating:

- i. PVC fusion coating
- ii. Thermoplastic powder coating

c. PVC liner

Runners:

- a. Glass reinforced polymer
- b. High-density virgin polyethylene

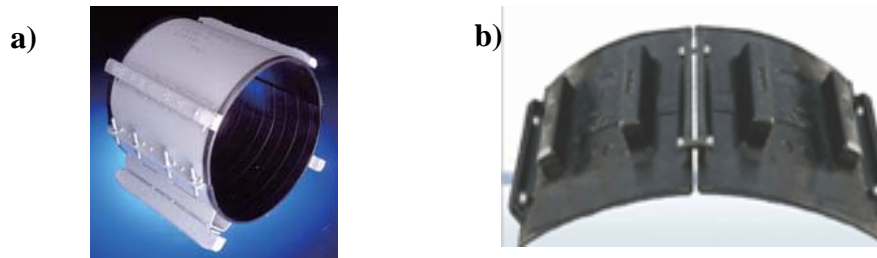

Figure 12. Casing isolation kit for metallic pipelines. Various sleeve materials are available including: (a) coated mild steel, and (b) high-density polyethylene. Nonmetallic runners prevent the metallic pipe from contacting the metal casing and causing an electrical short-circuit. The use of nonmetallic inner liners prevents damage to pipe and coating. (Courtesy of Pipeline Seal and Insulator, Inc.)

Dielectric Barrier Material

Dielectric material: Bitumastic 50, manufactured by Carboline, 350 Hanley Industrial Court, St. Louis, MO 63144, or equal, with the following essential characteristics:

1. Suitable for immersion.
2. Suitable for CP systems.

Warning Tape

Polyethylene warning tape (Figure 13) with the following essential characteristics:

1. Minimum of 3 inches wide.
2. Yellow or red with black lettering.
3. Suitable for direct burial.
4. “Caution–Cathodic Protection Cable Buried Below” printed on tape for its full length.



Figure 13. Warning tape used for marking location of CP cables.

Sand

Sand backfill: American Society for Testing of Materials (ASTM) C 33, fine aggregate.

Conduit

Galvanized steel or PVC conduit is used for anode, permanent reference electrode, structure, and test cables. Galvanized conduit is typically used for cables above grade, such as on the outside of tanks, and inside structures, such as buildings and vaults. Galvanized conduit should not be used for buried or submerged use. PVC conduit is used for cables below grade.

Submerged anodes mounted against the structure wall are typically placed in PVC conduit. The conduit is slotted and has perforation holes or cutouts on 180 degrees of the pipe, with a PVC end cap. Figure 14 shows an example of a conduit for mounting submerged anodes.



Figure 14. Conduit for mounting submerged anodes such as rod and wire anodes. Note the slots are only over 180 degrees of the circumference on one side of the pipe.

Galvanic Anode Systems

Anodes

Buried

Magnesium and zinc anodes (Figure 15) with the following essential characteristics:

1. Minimum of 20 pounds of bare anode material per anode unless otherwise stated in specification.
2. Specifically designed for CP systems and the intended environment.
3. Anode material meeting or exceeding the requirements of ASTM B 843 and B 418.
4. Contains a mild steel core that extends essentially the entire length of anode, centered within the anode material and exposed on one end of the anode, for the factory made anode-to-cable connection.
5. Anode cable in accordance with the requirements for cable section.
6. Anode prepackaged in a chemical backfill specifically intended for the type of buried anode used and wrapped in heavy paper or plastic for storage.
 - a. Chemical backfill: Approximately 75-percent ground hydrated gypsum, 20-percent powdered bentonite, and 5-percent anhydrous sodium sulfate.



Figure 15. Bare and bagged galvanic anodes. (Courtesy of CorrPro Companies, Inc.)

Submerged

Magnesium and zinc anodes are used for fresh water applications and come in various shapes such as plates, bars, rods, and ribbon (Figure 16). The anodes have the following essential characteristics:

1. The anode material specifically designed for the intended environment and listed in project specification.

- a. Brackish water zinc anodes are Type I.
 - b. Fresh water zinc anodes are Type II.
 - c. Magnesium anodes used in fresh water.
2. Anode material meeting or exceeding the requirements of ASTM B 843 and B 418.
 3. Rod and ribbon anodes contain a mild steel or galvanized mild steel core that extends essentially the entire length of anode, centered within the anode material and exposed on both ends of the anode, for the factory made anode-to-cable connections.
 4. Anode cable in accordance with cable requirements for cable section.

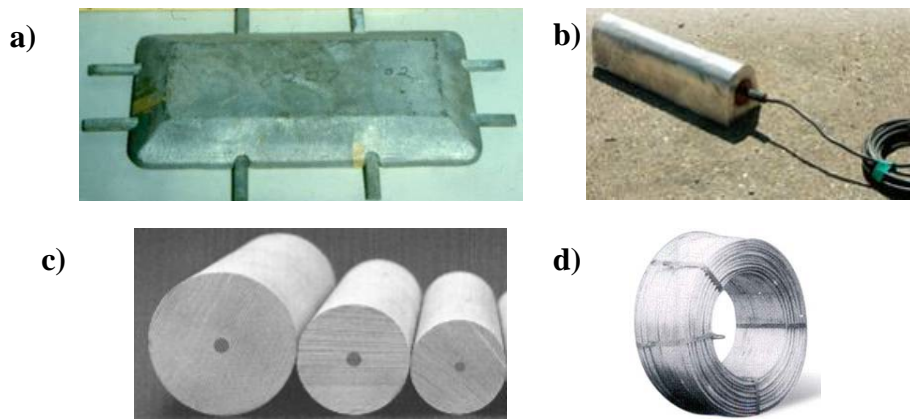

Figure 16. Galvanic anodes for use on submerged structures. Anode shapes include: (a) cast plate anode, (b) cast bar anodes, (c) extruded rod anodes, and (d) extruded ribbon anode. (Courtesy of Farwest Corrosion Control Company, CorroCont Ltd.)

Impressed Current Systems

Anodes

Buried

Impressed current anodes for buried use (Figure 17) are typically graphite and high silicon cast iron (HSCI). Also, a flexible linear anode (Figure 18), made of conductive-polymer coated copper, surrounded by high conductivity coke breeze, and held in place by a porous, woven, acid-resistant jacket. These anodes have the following essential characteristics:

1. Type and number of anodes given in project specification , section 26 42 1X.
2. Anode cable in accordance with cable requirements of this section.

3. The factory anode-to-anode cable connection, in addition to an internal moisture seal, is protected by epoxy encapsulation and an external anode cap.
4. Low resistance center cable connection having a waterproof seal on both sides of the anode-to-cable connection.

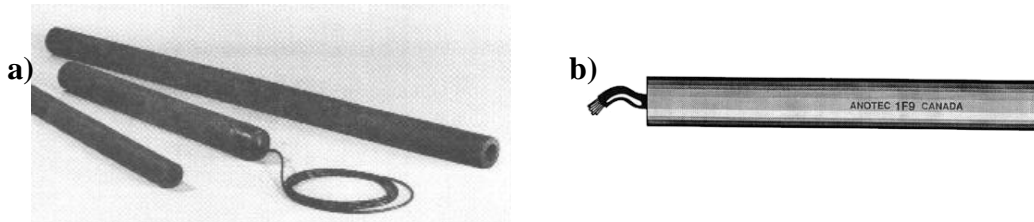

Figure 17. (a) Graphite impressed current anode, and (b) HSCI impressed current anode. (Courtesy of Farwest Corrosion Control Company)

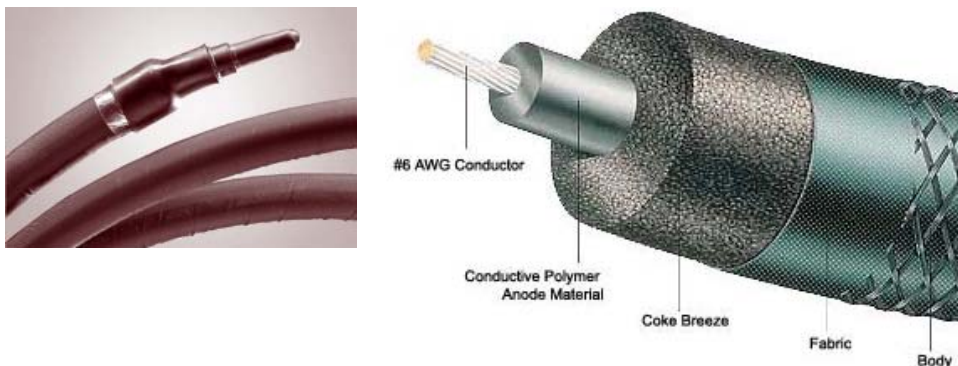

Figure 18. Linear anode of conductive-polymer coated copper, surrounded by high conductivity coke breeze, and held in place by a porous, woven, acid-resistant jacket. (Anodefex; courtesy of Farwest Corrosion Control Company).

Submerged

Anode materials used for submerged impressed current anodes include HSCI, platinized niobium, titanium rod, and mixed metal oxide (MMO). These materials are typically found as disk electrodes (Figure 19a); wire, pencil, and mesh electrodes (Figure 19b); stick or rod electrodes (Figure 19c); and through-wall probe electrodes (Figure 19d), with the following essential characteristics:

1. Anode cable in accordance with cable requirements of this section.
2. Anode-to-anode cable connection factory made and rated for submersion service.
3. MMO disk anodes secured into a nonmetallic dielectric shield.

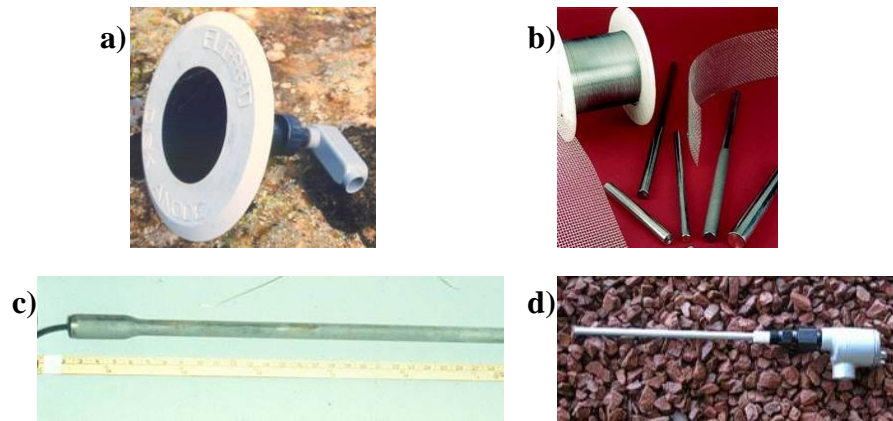

Figure 19. Examples of impressed current anodes include: (a) disk, (b) wire, pencil, and mesh; (c) stick or rod; and (d) through-wall probe electrodes. (Courtesy of Farwest Corrosion Control Company)

Rectifiers

Figure 20 shows an example rectifier used for an impressed current CP system. However, refer to the project specifications for the specific project rectifier. The rectifiers have, at a minimum, the following essential characteristics:

1. Air cooled.
2. Capable of continuous operation at 120 percent of rated output in ambient temperature of 50 degrees Celsius (°C).
3. Fitted with a heavy-duty transformer.
4. Silicon diode type.
5. Fitted with individual meters for determining output voltage and current, and which are:
 - a. Accurate within 2 percent of full scale.
 - b. Marked with red lines that designate rated capacities.
 - c. Output voltage is adjustable in 20 or more equal increments or continuously from 0 to 100-percent rated output.
6. Energized by 120 volts, single phase, AC.
7. Equipped with AC and DC lightning arrestors and protective fuses or relays.
8. Equipped with solderless, pressure-type terminals for anode and cathode cables.

9. NEMA 250, type 3-R, weatherproof, lockable, vented for heat dissipation cabinet, constructed of No. 16 gauge or thicker galvanized steel.
10. Equipped with a single slide-out rack for easy access to internal components during maintenance.
11. Equipped with an accessible shunt on the front panel for determining current output.
12. Fitted with a combination bracket for wall or pole mounting.
13. Screened against the entry of bees, hornets, or wasps.
14. External circuit breaker preceding and mounted on the same pole as the rectifier with shutoff switch and lockout/tagout capability for rectifiers installed outside of plant yards.

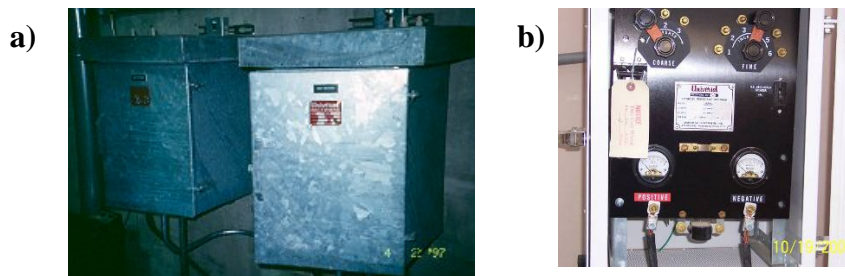

Figure 20. Rectifiers used for impressed current CP systems, showing: (a) galvanized enclosure, and (b) manual taps for adjusting the voltage.

Pea Gravel

1/8th-inch to 3/8th-inch smooth (no rough edges) pea gravel.

Vent Pipe

Deep well vent pipe, such as AllVent (Figure 21), manufactured by Loresco® International, 421 J.M. Tatum Industrial Park Drive, Hattiesburg, MS, 39401; or equal, having the following essential characteristics:

1. Nominal 1-inch inside diameter at surface.
2. Pipe below surface can be larger than 1 inch in diameter and sized as needed for depth of well and per cathodic protection specification section.
3. The vent pipe should be slotted within the coke backfill column and non-slotted outside the limits of the coke backfill column.

4. The slots should conform to one of the following requirements, while maintaining maximum pipe strength:
 - a. Vertical slits 1.5 inches in length with a width of 0.006 inch parallel to the longitudinal centerline of the pipe. Center-to-center spacing of 6 inches placed 1 inch in circumferential distance from the preceding slot, allowing for a 360-degree venting ability.
 - b. 1/8-inch holes drilled on 6-inch centers in the area of the anodes for the plastic vent pipe. Do not drill holes in the vent pipe above the anodes.
 - c. Schedule 40 PVC pipe with slots cut in the transverse direction 0.062 inch wide by 1.30 inches long as measured on the inside diameter of the pipe. The slots should be regularly spaced on the pipe in three columns with 1 inch of solid pipe between each open slot (measured along the axis of the pipe) to provide a minimum open area of 0.8 square inch per foot of vent pipe.
5. The vent pipe should have flush threaded joints per ASTM F 480 or solvent weld slip fit joints; reinforcement screws are not allowed.

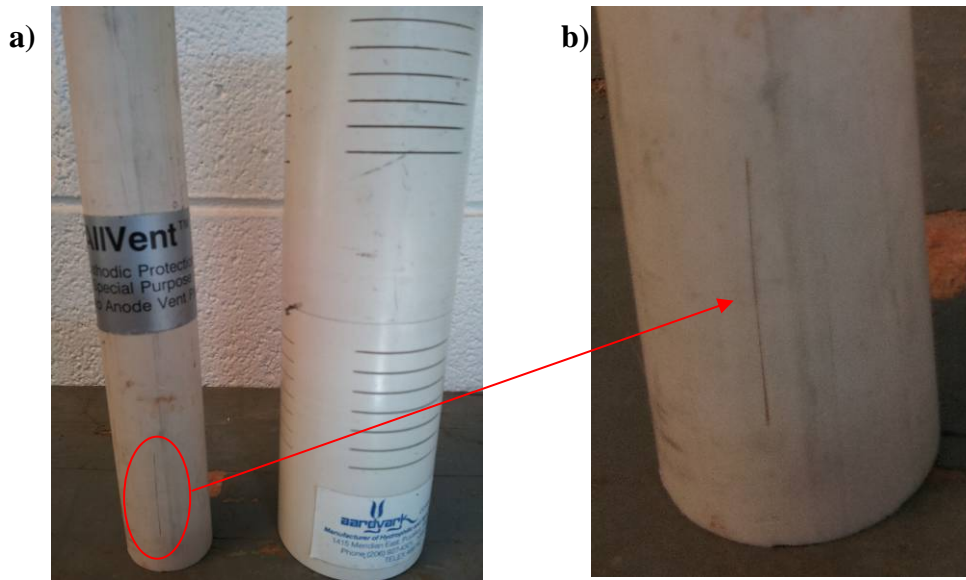

Figure 21. (a) Vent pipe with vertical and transverse slots for deep well anode beds and (b) circled area blown up to show vertical slot cut in the pipe.

Carbonaceous Backfill

Coke backfill: Use SC-3 calcined fluid petroleum coke as manufactured by Loresco[®], Inc. (Figure 22), 421 J.M. Tatum Industrial Park Drive, Hattiesburg, MS 39401; or equal, having the following essential characteristics:

1. Typical Chemical Analysis:

Component	Percent Composition
Carbon (fixed)	99.35 minimum
Ash	0.6 maximum
Volatiles	0 (950 °C)
Moisture	0.05

- The carbon content, as measured by the “loss of ignition method,” should be a minimum of 99.9 percent.
- Particle analysis: Dustfree with a maximum particle size of 1 millimeter.
- Fine spherical grained coke backfill to prevent bridging problems associated with installations into deep anode groundbeds.
- The bulk density should be between 62 and 66 pounds per cubic foot.
- The grain size should allow 90 percent to pass through a No. 4 screen and retain greater than 80 percent on a 20 mesh screen.
- The electrical resistivity should be less than or equal to 0.03 ohm-centimeters when compressed at 150 pounds per square inch.

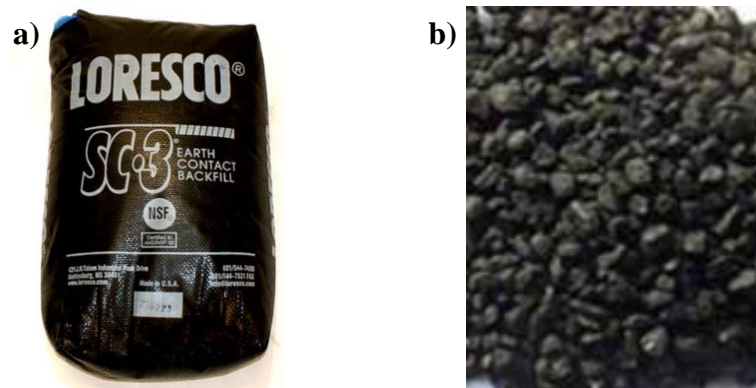

Figure 22. (a) Bag of petroleum coke backfill used for impressed current anode beds, and (b) spherical grained petroleum coke structure. (Courtesy of Norton Corrosion Ltd. and Alibaba.)

Anode Centralizing Devices

Anode centralizing device: Ventralizer (Figure 23), manufactured by Brance-Krachy Co., Inc., 4411 Navigation Boulevard, Houston, TX 77011; or equal, having the following essential characteristics:

1. The centralizer should be designed to hold the anode away from the vent pipe and sides of the drilled hole so that there is a minimum 1-inch-thick layer of coke backfill surrounding all surfaces of the anode. It should not block the hole or impair installation of the anode, anode wire, or coke breeze.
2. The centralizer should be constructed of carbon steel or stainless steel.



Figure 23. Example of device for centering anodes in deep well anode beds. Vent pipe can also be attached to the centralizer for easier installation. (Courtesy of Brance-Krachy Co., Inc.)

Grounding Rod and Cable

1. Must meet local electrical code requirements.
2. Minimum 10-foot-long, copper clad, steel ground rod with a $\frac{3}{4}$ -inch diameter.
3. No. 4 AWG or larger stranded copper ground cable, bare.
4. Bronze, bolt-on ground rod clamp if connection to ground rod is above grade; metallurgically bonded to the ground rod if connection is below grade.

Rectifier Protective Barriers

1. Rectangular barrier for field rectifiers:
 - a. Four pressure-treated, 8-foot-long, 4-inch-diameter wood posts.
 - b. Eight pressure-treated, 6-foot-long, 2-foot by 4-foot boards.

Chapter III

Installation

General Installation

The COR should inspect all materials prior to installation to ensure the proper, approved materials were received, handled, and stored in accordance with manufacturer's requirements. Installation and testing should be performed or directed by a Cathodic Protection Specialist certified by National Association of Corrosion Engineers International.

All buried structures (e.g., pipes and fittings) should be electrically isolated from all other metal (e.g. casings, foreign structures, and rebar in concrete), regardless of need for CP.

Cable

Inspection for Quality Control

Inspect and approve cable prior to installation. Inspect for insulation defects prior to backfilling, and ensure that cable is installed without kinks, stresses, and/or splices.

Exothermic Metallurgical Bonds

All cables and jumper bonds should be attached to structures by exothermic metallurgical bond. This may require the removal of a section of the structure's coating or lining. Bond in accordance with the bonding supply manufacturer's instructions and as described herein:

1. Bond integrity tested by **striking** (not tapping) side of weld nugget with a 16-ounce hammer. COR **should be** present for the first bonds and randomly throughout the process to ensure that they are performed correctly and tested.
2. Bare copper, weld nugget, and ferrous materials at metallurgical bonds should be coated with an approved dielectric metallurgical bond coating such as a Royston Handy Cap.
 - a. A primer is required in some instances such as cold weather.
3. After dielectric material has cured, the structure coating or lining should be repaired in accordance with the following:
 - a. Dielectric coatings/linings: Section 09 96 20 – Coatings.

b. Mortar/concrete coating and lining: USBR M-47.

Figure 24 is a schematic diagram depicting a proper weld procedure.

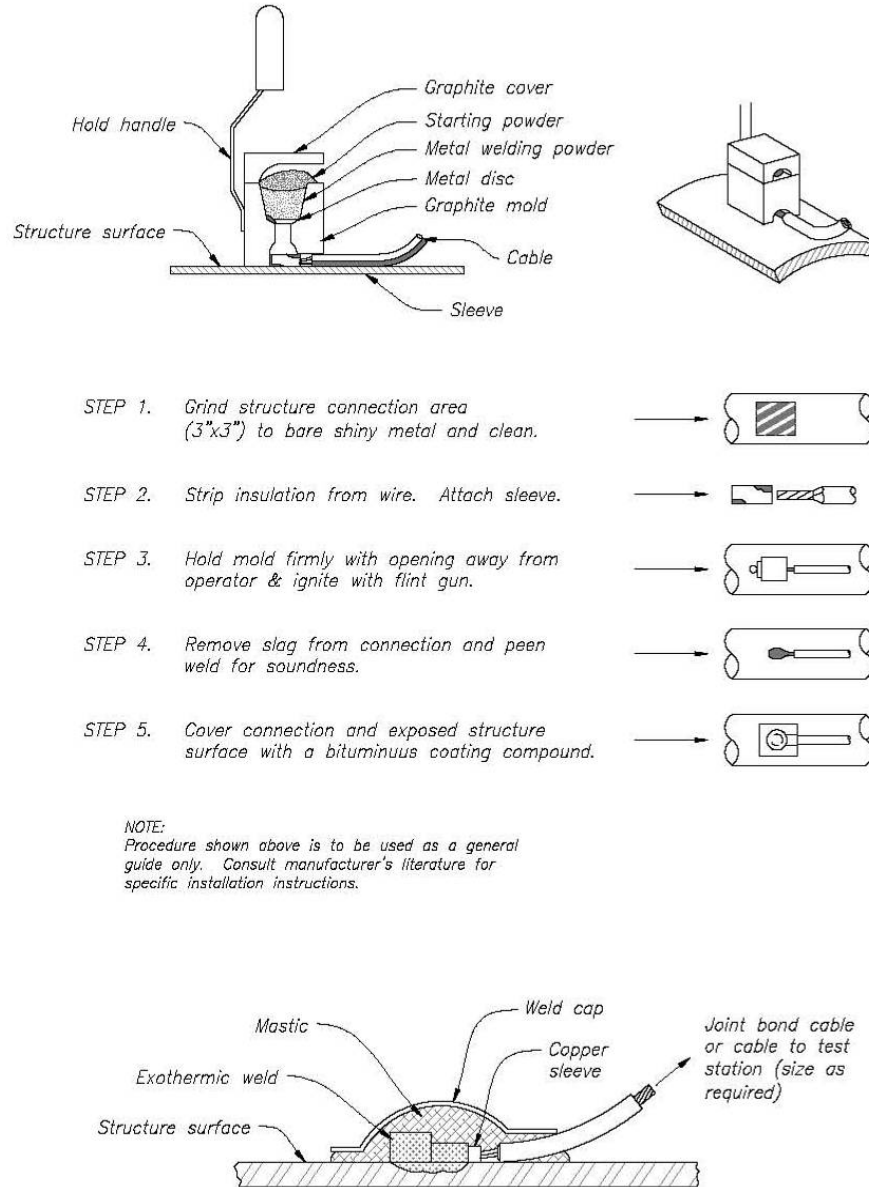

Figure 24. Schematic diagrams show the proper procedure for metallurgically bonding cables to metallic structures

Electrical Continuity Joint (Jumper) Bonds

Metallurgical bonds should be provided at all mechanical type joints (e.g., nonwelded joints) between ferrous parts in a CP system as indicated in this section or as necessary to ensure electrical continuity:

1. A minimum of two cables per bond joint unless otherwise stated in specification.
2. Bond cable installed with sufficient slack to prevent stress and allow for at least ½ inch of joint movement.
3. Jumper bond locations:
 - a. Nonwelded ferrous pipe sections and ferrous pipe and fittings.
 - i. Schematics for bonding flanged joints, push-on (bell and spigot) joints, and flexible coupling joints (figure 25).
 - ii. Schematic for bonding victaulic joints (figure 26).
 - iii. Schematic for bonding stargrips and fittings for PVC pipe (figure 27).
 - b. Reinforced concrete pipe bond jumpers should be welded on a 3.5- by 3.5-inch, square steel plate, factory welded to rebar.

Figure 28 shows properly installed bonds for mortar coated pipe, buried flanged pipe, and atmospherically exposed pipe.

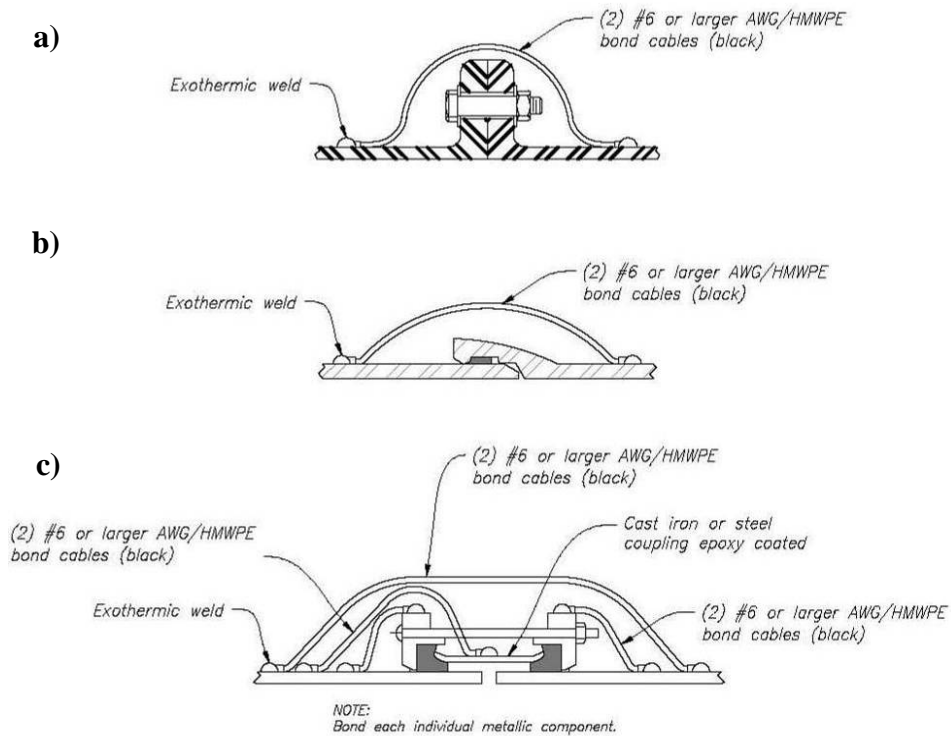

Figure 25. Schematic shows jumper bond installation for: (a) a flanged joint (nonisolating), (b) a push-on joint, and (c) a flexible coupling (multiple component coupling).

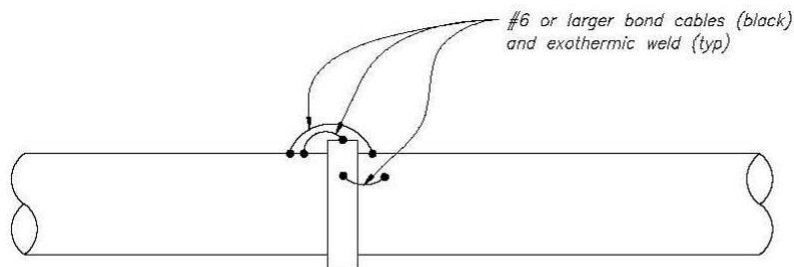

Figure 26. Schematic shows jumper bond installation for Victaulic joints.

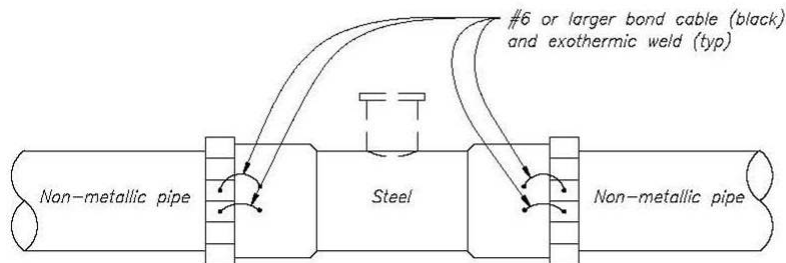

Figure 27. Schematic shows jumper bond installation for PVC to steel fitting.

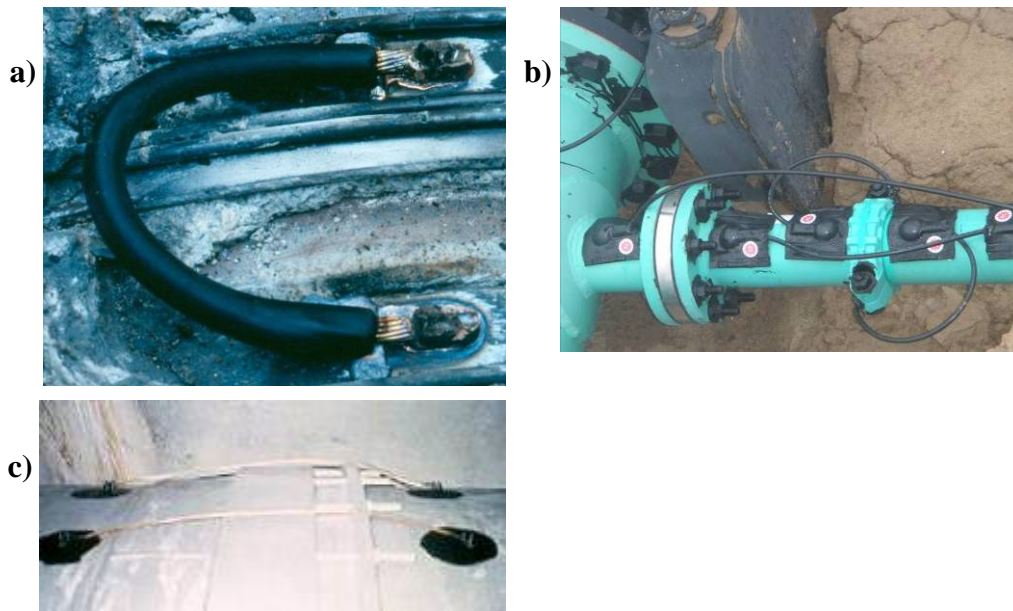

Figure 28. Examples of jumper bonds for various pipe situations: (a) The mortar coating was removed at the joint to attach the jumper bond; (b) jumpers were installed on the pipe across the various joints, and the weld nuggets were covered with bitumastic molded cap (Handy Cap) prior to burial; and (c) bonds were installed across the expansion joint on an outlet works pipe, and the weld nuggets were coated with a bitumastic coating.

Structure Cables

There should be one test cable and one bond cable per structure at each test station. Cables should be connected to test station, rectifier, and junction box terminals with crimped, ring-tongue connectors.

Buried Applications

All horizontal segments of cable should be buried in accordance with the following requirements and as shown in figure 29:

1. Bury to a minimum depth of 30 inches standard; 42 inches for cables in agricultural fields.
2. Ensure that the cable is surrounded with a minimum of 6 inches of sand backfill.
3. Place warning tape approximately 12 inches above cable for the entire length of cable segments.
4. Ensure that no sharp objects are pressing against the wire.

5. Run above-grade cables through rigid galvanized conduit, test station pipe, or similar protection.

Figure 30 shows an example of warning tape installation.

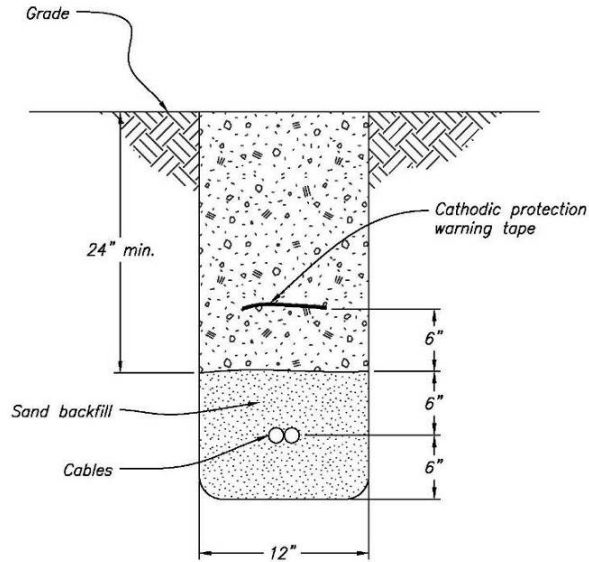

Figure 29. Schematic for installation of buried cables. Cables in agricultural fields should be buried at a minimum depth of 42 inches (1 foot deeper).



Figure 30. Installation of warning tape in a cable trench.

Cable Identification

The origin of all cables terminating an enclosure should be clearly identified in accordance with the following requirements and as shown in figure 31:

1. Factory printed letters on self-adhesive strips attached to the cables should be clearly visible within the enclosure.
2. Labels should be encased in clear heat shrink tubing.

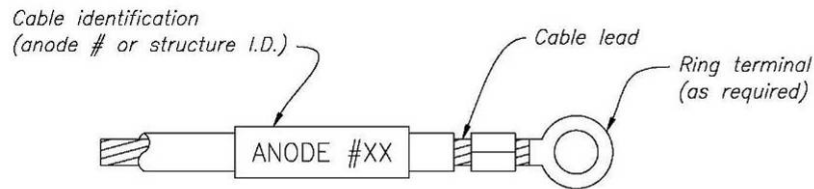

Figure 31. Schematic for identifying and labeling all cables terminating in test stations, junction boxes, and rectifiers.

Electrical Isolation (Insulation)

General

Pipe and fittings should be electrically isolated from all other metal (e.g. casings, foreign structures, and rebar in concrete).

Isolation Joint Flange Kit

Installation

Inspection and observation of the installation of the flange isolation kits should be conducted to ensure the following:

1. The installation kits contain the material specified, and the contents are not damaged.
2. Flanges are free of pits, gouges, rust, debris, oil and grease. Surface finish should be no greater than 250 RMS (root mean squared or roughness average). Flange faces should be refinished if corrective measures do not meet the foregoing.
3. The flange and bolt hole spot facings do not have burrs, etc.
4. When the insulating sleeves are inserted, they are not forced into the holes, which could damage the sleeve material.
5. A nonconductive lubricant is applied to all threads and flange side of nuts.
6. The bolts are inserted with both insulating washers against the flanges, followed by the steel washer and nut as shown in figure 32.
7. Tightening of the bolts is in accordance with manufacturer's requirements, the following criteria, and as shown in figure 33:
 - a. Bolts should be tightened with torque wrenches (mechanical and hydraulic) or with a stud tension measuring device.

- b. Initially cross-tighten bolts until flange-to-gasket contact has been made.
 - c. Tighten all bolts initially to 10-15 percent of specified torque.
 - d. Then, tighten all bolts to 50 percent of specified torque.
 - e. Finally, tighten all bolts to 100 percent of final torque value.
 - f. The same basic procedure, as shown in figure 33, should be used with flanges having more or less bolts.
 - g. It is always a good policy to go completely around flange, checking bolt to bolt for proper torque, particularly on large diameter piping systems.
8. Bolts of sufficient length to extend through the nut approximately $\frac{1}{4}$ inch.

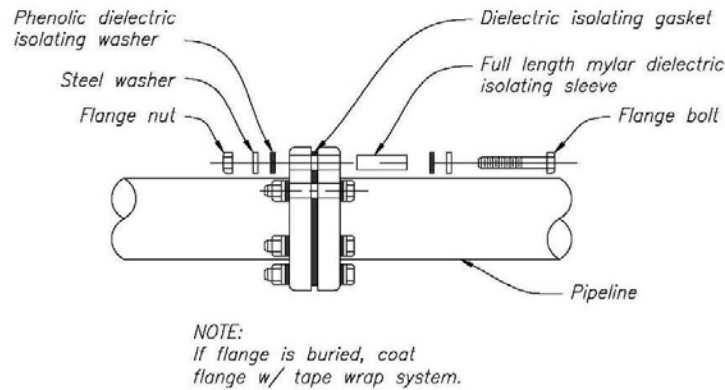

Figure 32. Schematic shows isolation bolt installation for isolation flange kit.

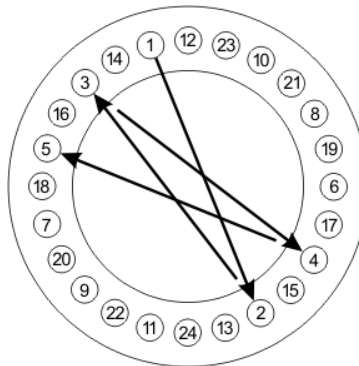

Figure 33. Schematic shows bolt tightening sequence to provide even sealing pressure on a flange gasket.

Ensure buried isolated pipe flanges are coated with an external wax-tape coating in accordance with AWWA C217 and as modified herein:

1. The wax-tape coating is not applied until the isolated pipe flange has been tested and approved.
2. Surface primer application:
 - a. The surface is cleaned of dirt, dust, and loose rust by wire brush and by wiping with a clean cloth until dry.
 - b. The primer is applied by hand or brush working a thin coating of primer into all crevices, i.e., around all bolts and in threads, and completely covering all exposed metal surfaces.
 - c. Primer is extended a minimum of 2 pipe diameters onto the adjacent surfaces of the pipe or valve.
3. Wax tape application:
 - a. Wax tape applied immediately after the primer application.
 - b. Short lengths of tape placed completely around each bolt head and nut, working the tape into the crevices around the bolts and nuts.
 - c. The wax tape is wrapped spirally around the pipe and across the flanges to adjacent pipe or valve with a minimum overlap of 55 percent of tape width.
 - d. The tape is worked into the crevices and contours of the irregularly shaped surfaces and smoothed out so that there is a continuous protective layer with no voids or spaces under the tape.
 - e. All surfaces and edges are coated with wax tape having a minimum thickness of 100 mils.
4. Outer covering:
 - a. The wax tape is overlapped with two layers of polyvinylidene chloride, high cling plastic membrane sheet, such that the material conforms and adheres to the wax tape surface.
 - b. The plastic wrap is secured to the pipe with adhesive tape.

Testing

1. The contractor should test the electrical isolation effectiveness of each insulated pipe flange after installation using a Gas Electronics Model 601

insulation tester (figure 34a), manufactured by M.C. Miller Co., Inc., 11640 U.S. Highway 1, Sebastian, FL 32958; or equal.

- a. Across flange.
 - b. Each individual bolt.
 - c. If the insulated pipe flange will be buried, it should be tested for electrical isolation before the wax-tape coating is applied.
2. The COR may request the contractor to test the electrical isolation effectiveness of each insulated pipe flange during or immediately after burial of the flange using a Gas Electronics Model 702 insulation tester (figure 34b), manufactured by M.C. Miller Co., Inc., 11640 US Highway 1, Sebastian, FL 32958; or equal.
 3. The contractor should replace or repair any insulated pipe flange that is determined electrically ineffective.

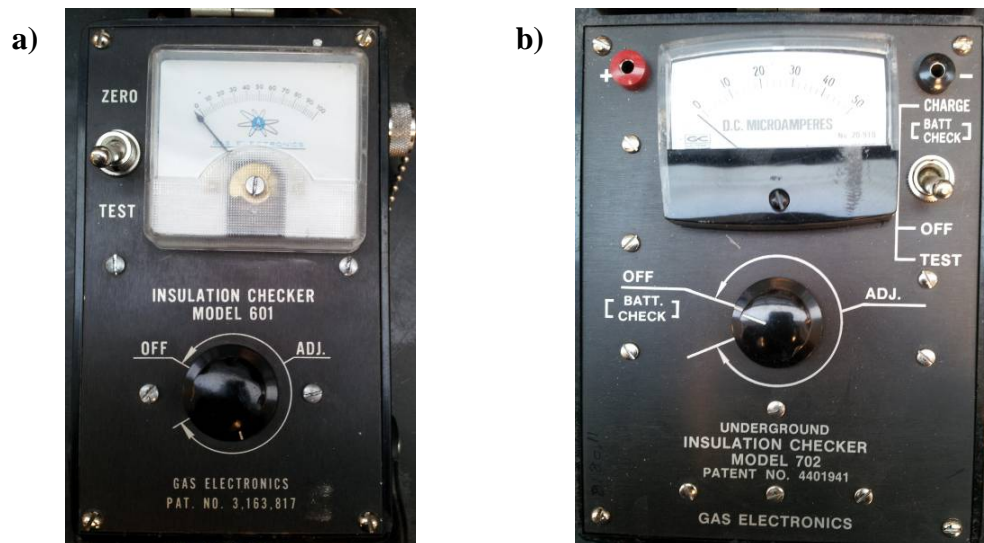

Figure 34. Test instruments for ensuring proper installation and operation of isolation (insulation) joints flange kits: (a) Model 601 is for testing aboveground joints, and (b) Model 702 is for testing joints underground.

Casing Isolation

Installation

Metallic pipe should be electrically isolated from casing using nonmetallic spacers and nonmetallic sleeves when necessary. Casing isolators should be installed according to the manufacturer's instructions and the following:

1. Isolation sleeves are spaced to prevent sagging of the pipe, and the pipe is centered inside the casing.
2. During the installation operation, ensure that no isolator or spacer displacement or damage to the carrier pipe coating exist. Continue the push/pull operation in a smooth motion until the carrier pipe is properly positioned.
3. Isolator runners (skids) are oriented properly, and all bolts, if present, should not remain at the bottom (6 o'clock) position.
4. Casing end seals are installed on both ends of casing to ensure water and backfill do not fill the annular space.
5. Ensure that carrier pipe is electrically isolated from casing after installation.
6. Annular space is either left empty, grouted, or filled with dielectric material composed mainly of petrolatum wax or petroleum-based compounds that contains corrosion inhibitors, plasticizers, and thermal extenders.

Figure 35a is an illustration of a completed installation. Figure 35b shows casing isolation spacers installed on a diameter steel pipe.

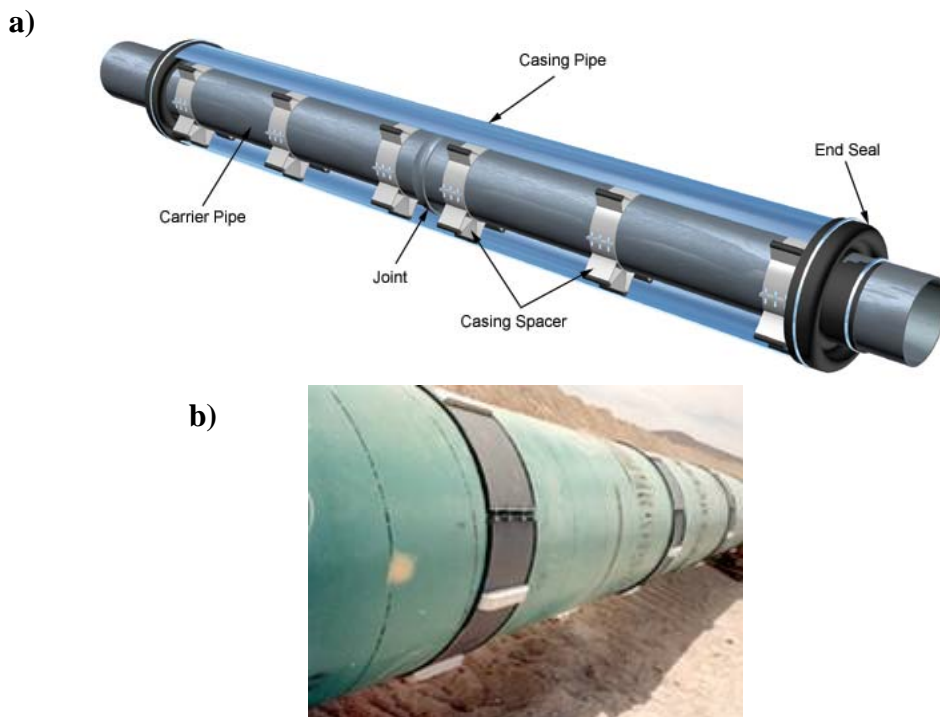

Figure 35. (a) Casing installation, including spacers and end seals; and (b) casing isolators installed on a coated steel pipe.

Testing

1. The contractor should test the electrical isolation effectiveness of the casing isolators after pipe installation, and prior to end seal installation and burial, using a Gas Electronics Model 601 insulation tester (figure 34a), manufactured by M.C. Miller Co., Inc., 11640 U.S. Highway 1, Sebastian, FL 32958; or equal.
2. The contractor should test the electrical isolation effectiveness of the casing isolators after burial using a Gas Electronics Model 702 insulation tester (figure 34b), manufactured by M.C. Miller Co., Inc., 11640 U.S. Highway 1, Sebastian, FL 32958; or equal.
3. The contractor should repair any casing installation that is determined electrically ineffective.

Test Stations and Junction Boxes

Locations

Locations of test stations for corrosion monitoring and/or CP:

1. At each end of any electrically continuous pipeline.
2. Approximately every 1,000 feet for long electrically continuous segments of pipeline.
3. At one end of all casings.
4. At all foreign pipeline crossings.
5. At all sets of bonded metallic fittings on nonmetallic pipe.
6. At all bonded structures (buried yard metalwork, tanks, etc.)
7. As close to structure as possible.
8. Located to make them readily accessible.
9. Where test stations will not likely be damaged or interfere with personnel and/or equipment (e.g., adjacent to aboveground structures).

Exact location is subject to approval of COR.

Corrosion Monitoring

Test station should meet the following requirements:

1. PVC pipe is installed such that 4 feet of the pipe are below grade with cross bar inserted as shown in figure 36a.
2. Protect by a triangular barrier outside of plant yards:
 - a. Test stations are not installed inside of agricultural fields.
3. Permanently, uniquely, and clearly identify:
 - a. Stationing.
 - b. Global Positioning System (GPS) coordinates.
4. Contain two cables as shown in figure 36b.
 - a. No. 6 AWG bond cable from the structure for determining structure-to-soil potentials and for connecting to galvanic anode(s) if required.
 - b. No. 12 AWG test cable from the structure for determining structure-to-soil potentials.
5. Ensure that all cables for a given location terminate within the same test station enclosure.
6. All cables identified as to the distinct originating structure as described in the “Cable” section.

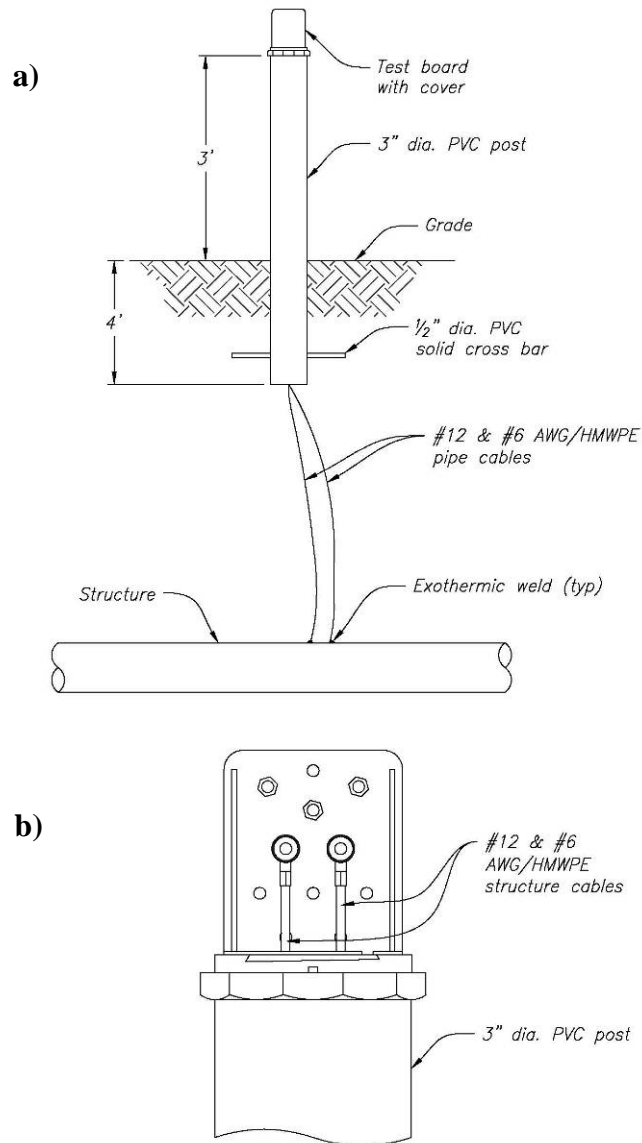

Figure 36. Drawing of test station installation for corrosion monitoring: (a) plan view of test station, and (b) close-up view of the test board.

Isolation Joints

Test station should meet the following requirements:

1. PVC pipe is installed such that 4 feet of the pipe are below grade with cross bar inserted as shown in figure 37a.
2. Protected by a triangular barrier outside of plant yards:
 - a. Test stations are not installed inside of agricultural fields.
3. Permanently, uniquely, and clearly identified:
 - a. Stationing.
 - b. GPS coordinates.
4. Contain four cables as shown in figure 37b.
 - a. No. 6 AWG bond cable from each side of isolation joint for determining structure-to-soil potentials and for connecting to galvanic anode(s) or resistance bond if required.
 - b. No. 12 AWG test cable from each side of isolation joint for determining structure-to-soil potentials.
5. Ensure that all cables for a given location terminate within the same test station enclosure.
6. All cables identified as to the distinct originating structure as described in the “Cable” section.

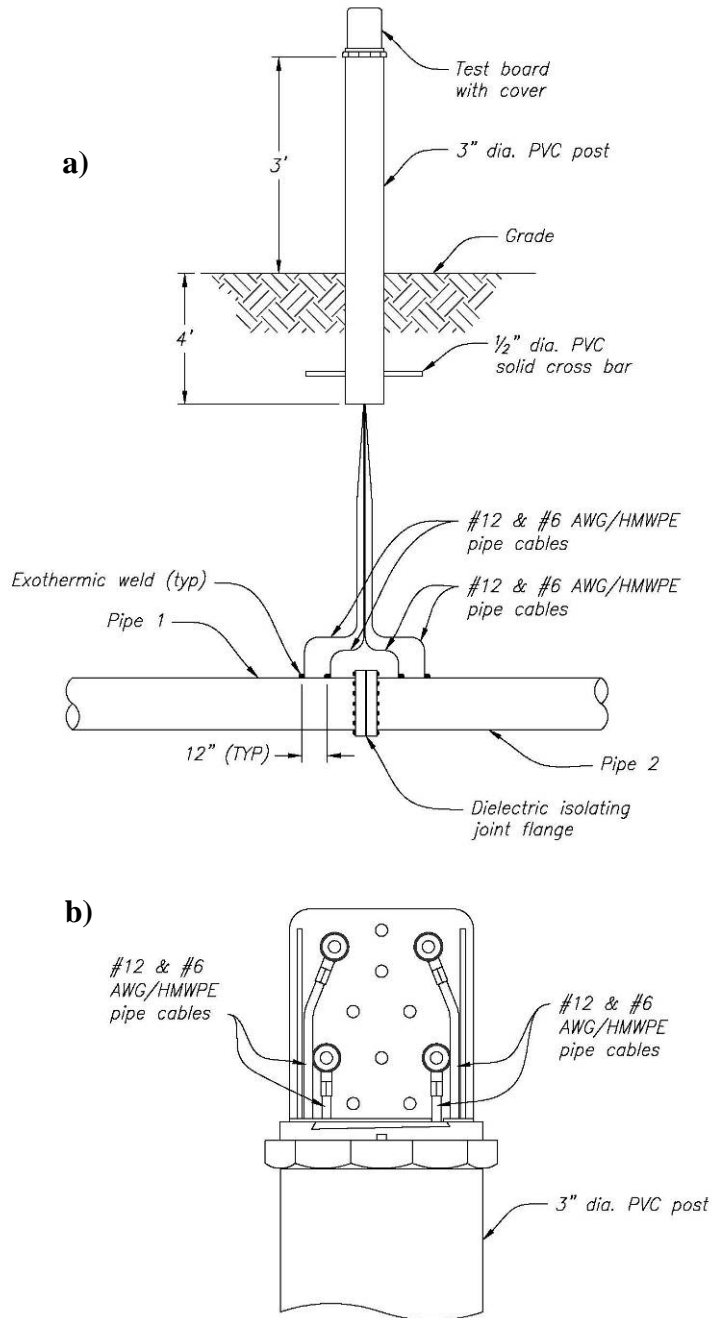

Figure 37. Drawing of test station installation for isolation joint: (a) plan view of test station, and (b) close-up view of the test board.

Casings

Test station should meet the following requirements:

1. PVC pipe is installed such that 4 feet of the pipe are below grade with cross bar inserted as shown in figures 38a and 39a.
2. Protected by a triangular barrier outside of plant yards:
 - a. Test stations are not installed inside of agricultural fields.
3. Permanently, uniquely, and clearly identified:
 - a. Stationing.
 - b. GPS coordinates.
4. Test station should include two cables from the casing, two cables from carrier pipe (if metallic), and one cable from each anode required for casing and pipe as shown in figures 38b and 39b.
 - a. No. 6 AWG bond cable from casing and carrier pipe (if metallic) for determining structure-to-soil potentials and for connecting to galvanic anode(s) if required.
 - b. No. 12 AWG test cable from casing and carrier pipe (if metallic) for determining structure-to-soil potentials.
5. Anode cables connected through a 0.01 ohm calibrated shunt and a variable resistor (as necessary) for each anode in the test station.
 - a. Anodes are not required on carrier pipe if it is PVC.
 - b. Anodes are not required on carrier pipe if protected by an impressed current CP system at said location.
6. Ensure all cables for a given location terminate within the same test station enclosure.
7. All cables identified as to the distinct originating structure as described in the "Cable" section.

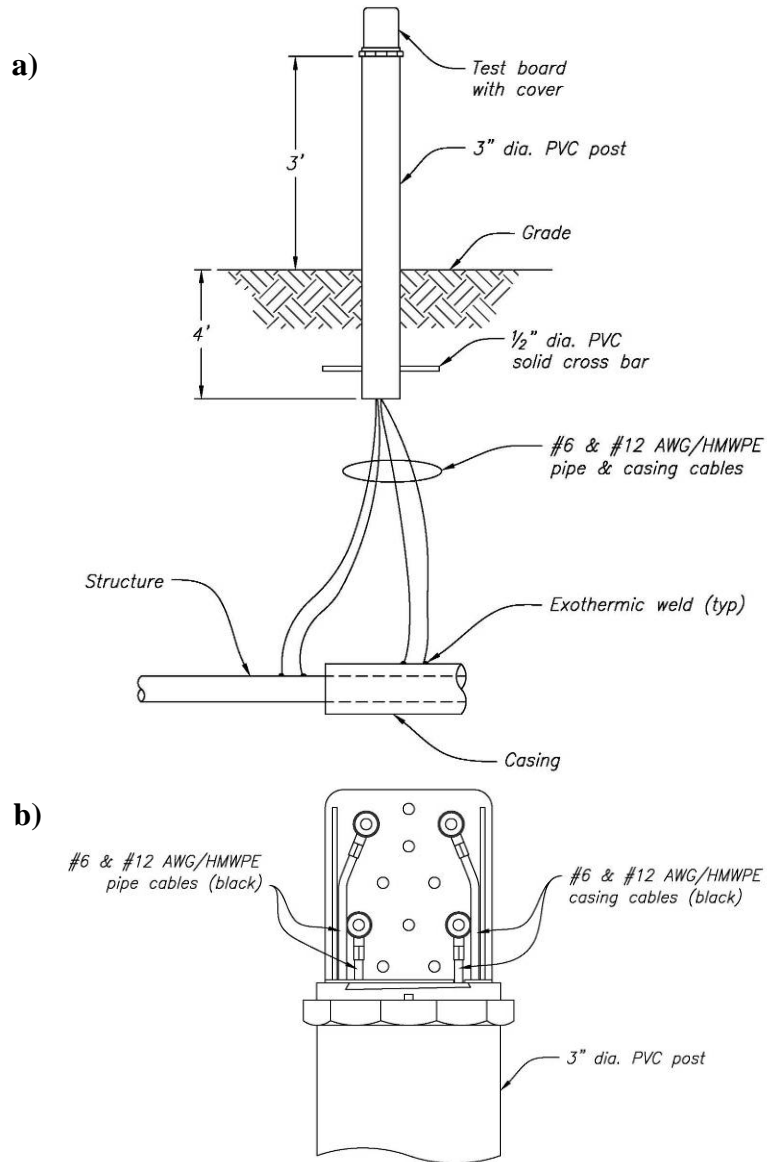

Figure 38. Drawing of test station installation for a casing: (a) plan view of test station, and (b) close-up view of the test board.

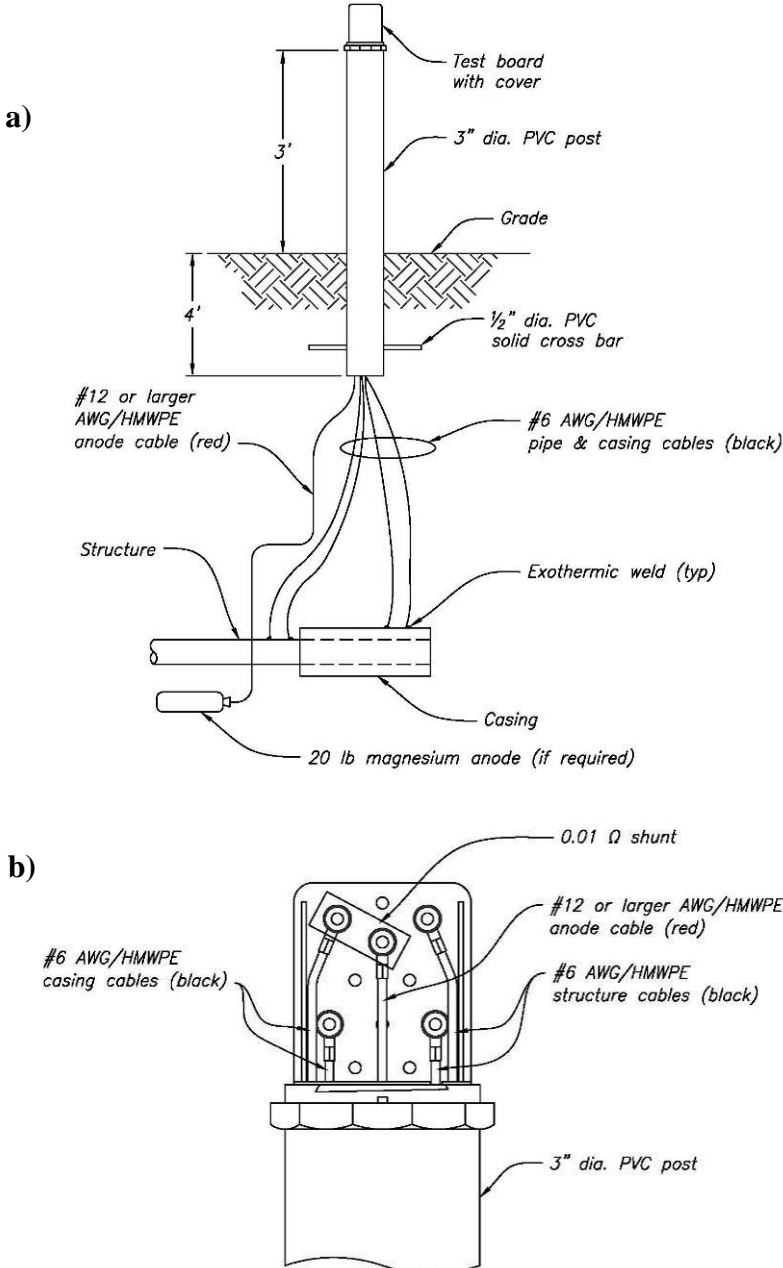

Figure 39. Drawing of test station installation for a casing with galvanic anode: (a) plan view of test station, and (b) close-up view of the test board.

Foreign Line Crossings

Test station should meet the following requirements:

1. Only required if both foreign pipeline and Reclamation pipeline are metallic and an impressed current system is installed on one or both pipes.
2. PVC pipe is installed so that 4 feet of the pipe are below grade with cross bar inserted as shown in figure 40a.
3. Protected by a triangular barrier outside of plant yards:
 - a. Test stations are not installed inside of agricultural fields.
4. Permanently, uniquely, and clearly identified:
 - a. Stationing.
 - b. GPS coordinates.
5. Test station should include two cables from each pipeline and one cable from a permanent reference electrode as shown in figure 40b:
 - a. No. 6 AWG bond cable from each pipe for determining structure-to-soil potentials and for installing a resistance bond or connecting to galvanic anode(s) if required.
 - b. No. 12 AWG test cable from each pipe for determining structure-to-soil potentials.
 - c. Ensure permission is obtained from the foreign pipe owner prior to attaching cables on foreign line.
6. Permanent Cu/CuSO_4 reference electrode placement:
 - a. Between the foreign pipe and the Reclamation pipe.
 - b. Approximately 12 inches from the Reclamation pipe.
 - c. Installed in accordance with manufacturer's instructions.
7. Ensure that all cables for a given location terminate within the same test station enclosure.
8. All cables identified as to the distinct originating structure as described in the "Cable" section.

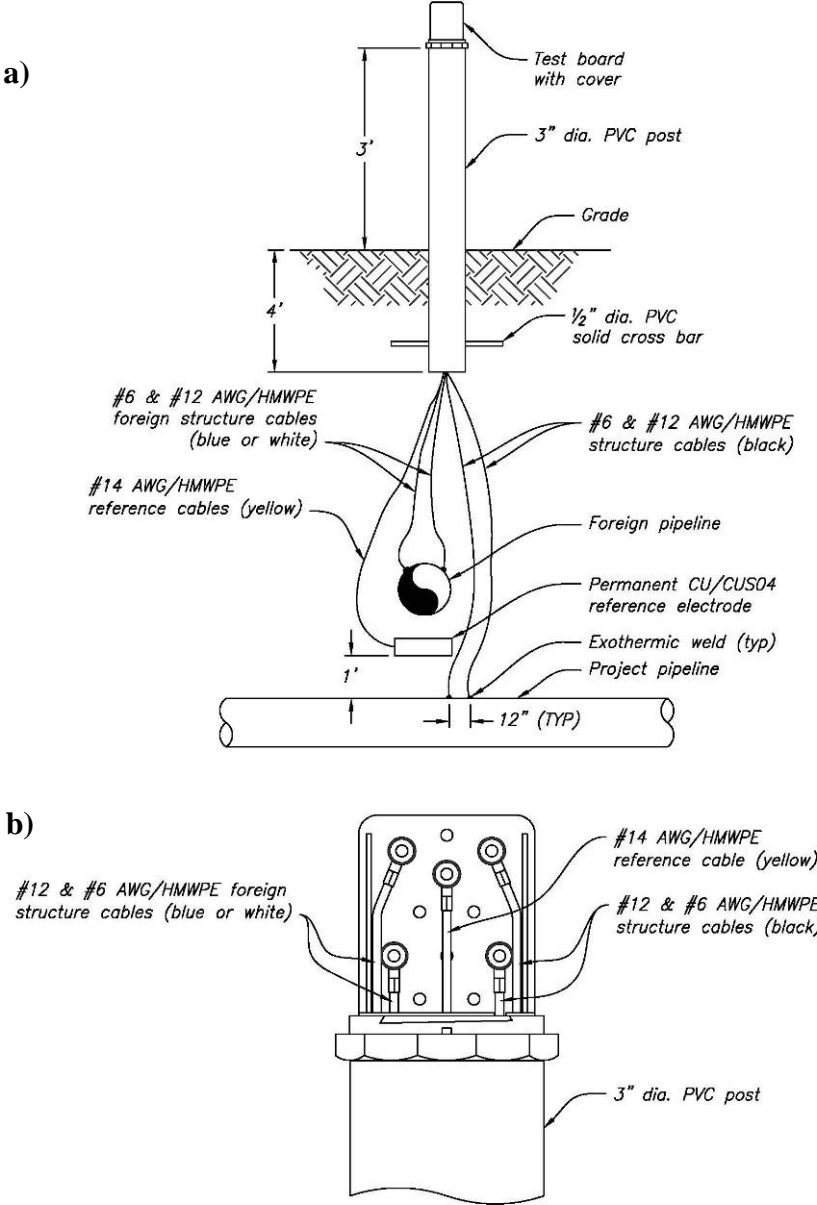

Figure 40. Drawing of test station installation for a foreign line crossing: (a) plan view of test station, and (b) close-up view of the test board.

Galvanic Anode(s)

Test station and junction boxes should meet the following requirements:

1. PVC pipe is installed so that 4 feet of the pipe are below grade with cross bar inserted as shown in figures 41a, 42a, and 43a.
2. Protected by a triangular barrier outside of plant yards:
 - a. Test stations are not installed inside of agricultural fields.
3. Permanently, uniquely, and clearly identified:
 - a. Stationing.
 - b. GPS coordinates.
4. Test station should include three cables minimum, two from the pipeline and one cable from each anode as shown in figures 41b, 42b, and 43b.
 - a. No. 6 AWG bond cable from pipe for connecting to galvanic anode(s).
 - b. No. 12 AWG test cable from pipe for determining structure-to-soil potentials.
 - c. No.12 AWG anode cable, one from each anode:
 - i. Each anode cable connected to bond cable through shunt.
 - ii. Each anode cable connected through variable resistor (if necessary).
 - iii. Junction box required for locations with large numbers of anodes.
5. Ensure that all cables for a given location terminate within the same test station enclosure.
6. All cables identified as to the distinct originating structure as described in the “Cable” section.

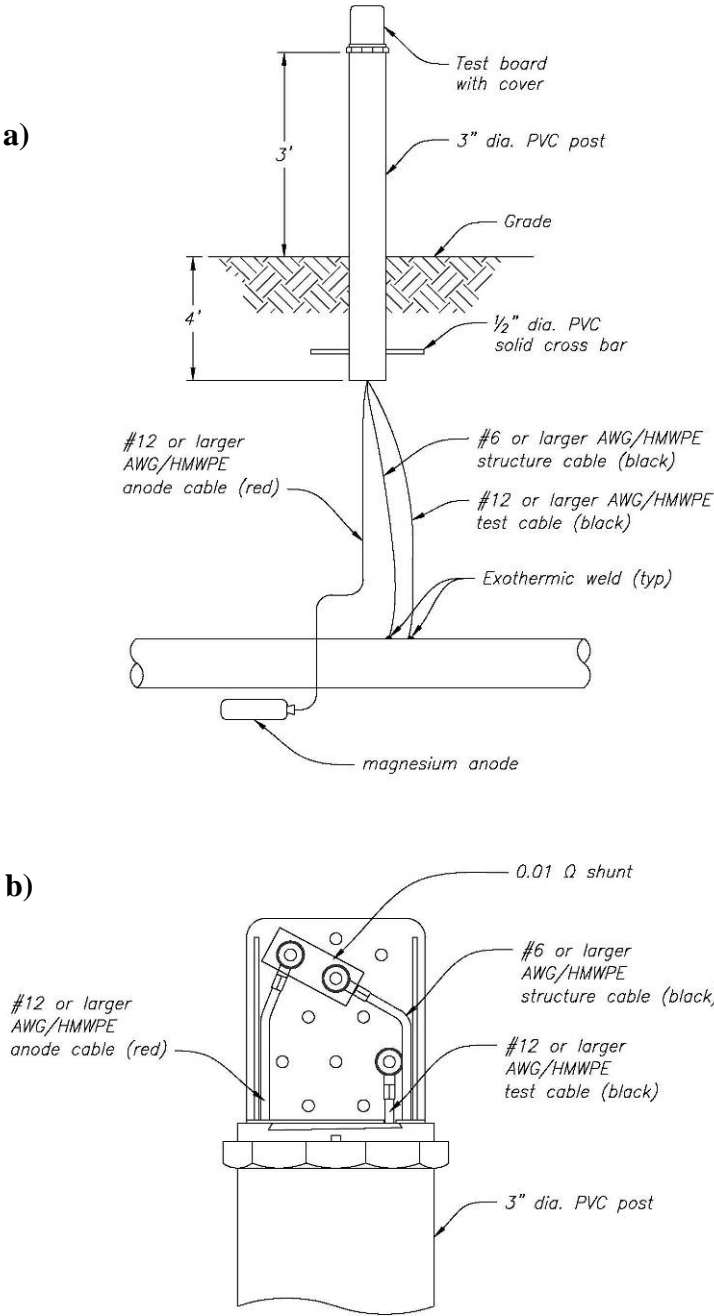

Figure 41. Drawing of test station installation for a single galvanic anode: (a) plan view of test station, and (b) close-up view of the test board.

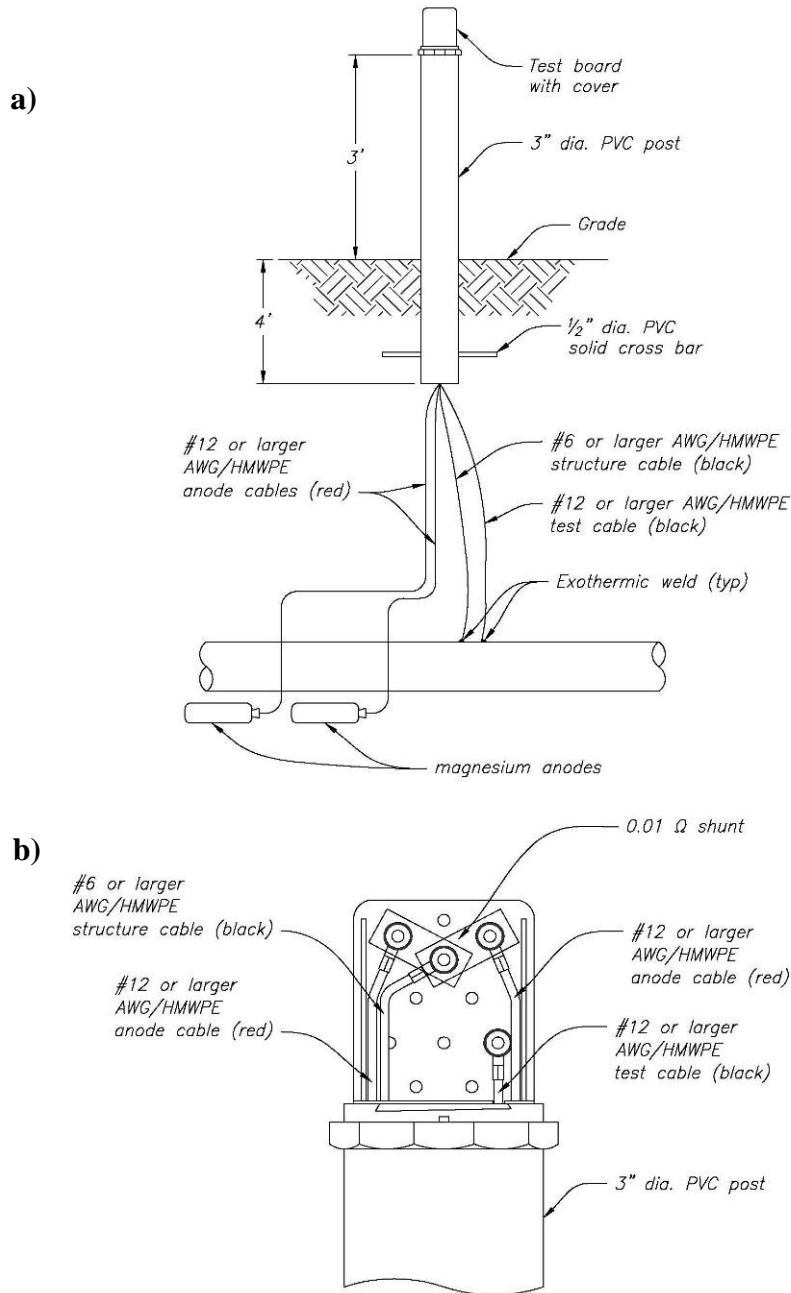

Figure 42. Drawing of test station installation for multiple galvanic anodes: (a) plan view of test station, and (b) close-up view of the test board.

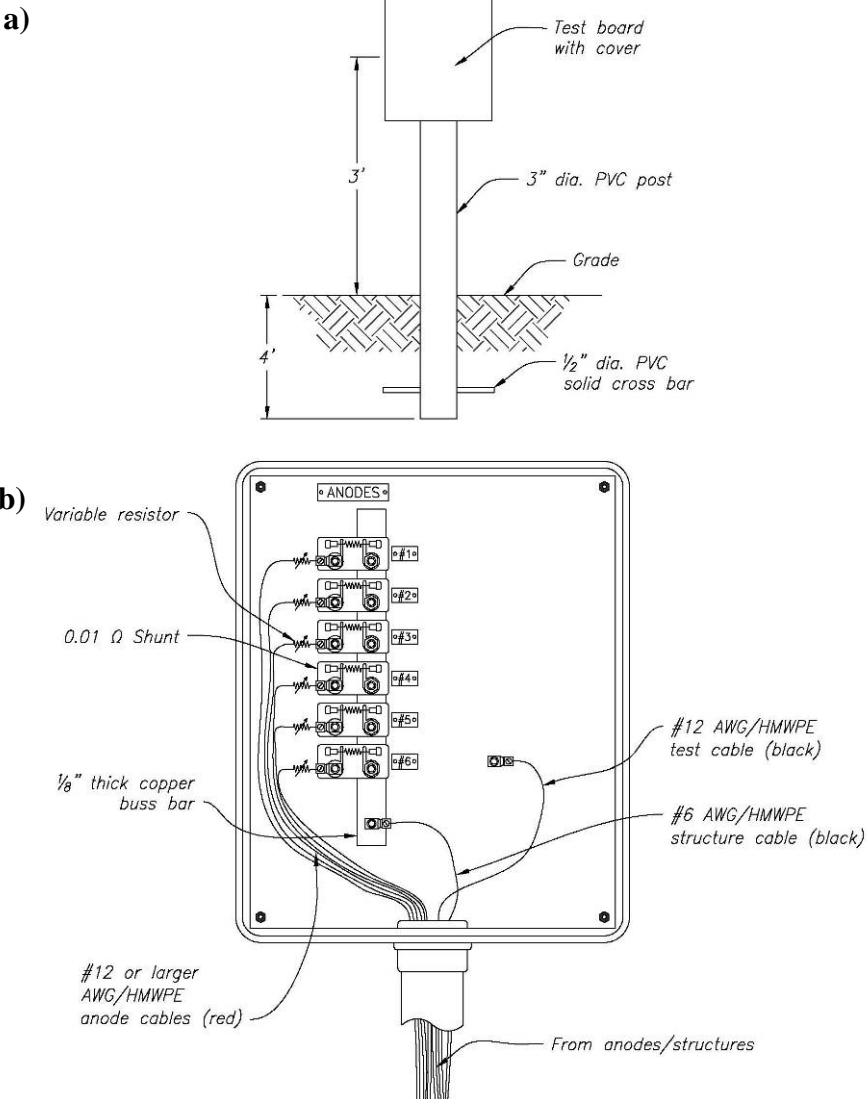

Figure 43. Drawing of junction box installation for multiple galvanic anodes: (a) plan view of junction box, and (b) close-up view of the anode panel.

Barriers

Triangular Barriers

Figures 44a and b show triangular steel barriers used for protecting test stations and junction boxes. The barriers should meet the following criteria:

1. Standpipes spaced 3 feet apart.
2. Steel standpipes buried 3.5 feet below grade such that 3.5 feet are above grade.
3. Crossbars welded to steel standpipes 6 to 8 inches below top of standpipes.
4. Standpipes capped or filled with concrete.
5. Standpipes embedded in concrete footers 8 inches in diameter by 1.5 feet high.
6. Exposed steel coated “safety yellow.”
7. Test station centered in barrier.

Rectangular Barriers

Figures 45a and b show rectangular wood barriers used for protecting rectifiers. The barriers should meet the following criteria:

1. Posts spaced 6 feet apart.
2. Posts buried 3 feet below grade such that 5 feet is above grade.
3. Two-foot by 4-foot crossbars attached to posts at heights of 2.5 feet and 4.5 feet.
4. Rectifier centered in barrier.

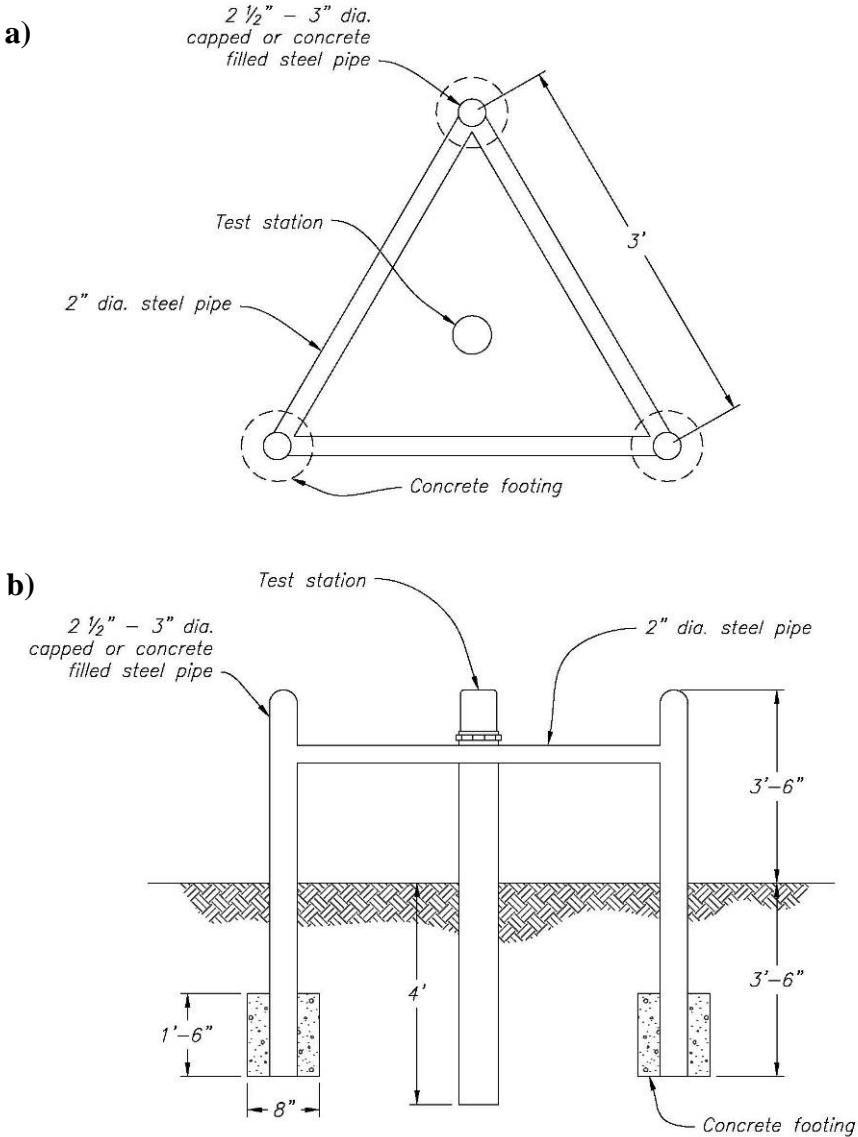

Figure 44. Triangular test station design for protecting test stations and junction boxes from damage. Barrier constructed of welded steel pipe and coated "safety yellow."

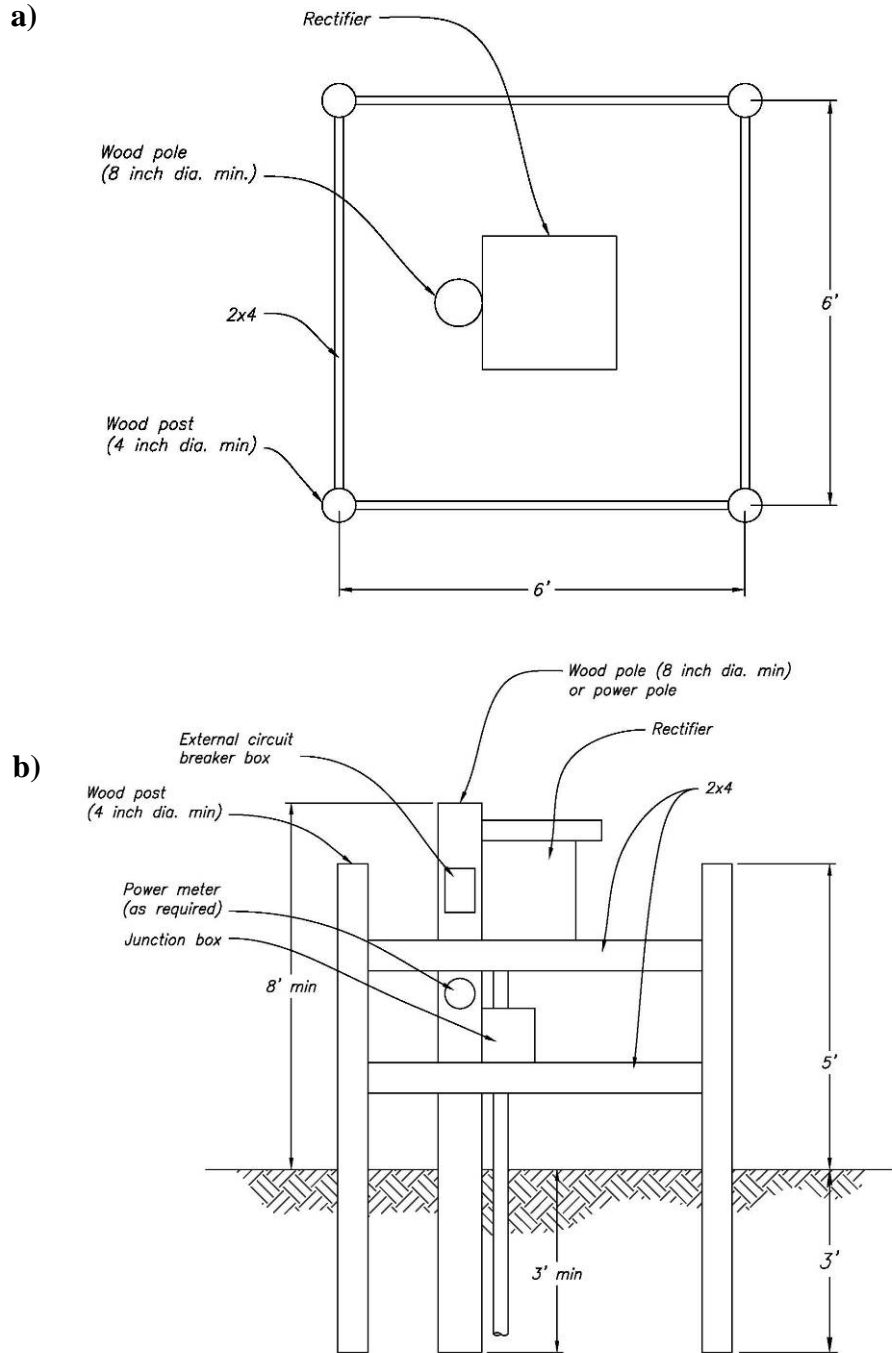

Figure 45. Rectangular barriers for safety and preventing damage to rectifiers outside of plant yards. Barriers constructed of pretreated wood.

Galvanic Anode Systems

Buried Anodes

Anodes are to be installed as follows:

1. Refer to specification for details on number and location of anodes.
2. Installed horizontally or vertically and as directed by the COR.
3. At least one anode length from any nonmetallic piping.
4. Depth at or below invert of piping.
5. Removal of outer water-resistant covering on the prepackaged anodes prior to installation, taking care not to damage the wettable covering.
6. Prepackaged anodes not wetted until in the ground and surrounded with at least 1 foot of compacted earth.
7. Anodes are not connected to structures at test stations or junction boxes at the time of installation.
8. Calibrated 0.01 ohm shunts supplied within the test station or junction box for each individual anode.
9. Variable resistors supplied within the test station or junction box for each individual anode when required.
10. Anodes placed on structures greater than 50 feet inside irrigated fields directly attached to the structure and no test station provided.

Submerged Anodes

General

Galvanic anodes should not be coated.

Suspended

1. For specific anode installation locations, refer to project specifications.
2. Anodes installed horizontally (figures 46a and b) or vertically (figures 47a and b).
3. Hung from nonmetallic support ropes at the top and bottom of the anode so that the anode(s) are not in contact with any part of the structure.

4. Where support ropes hold the anodes, wrap anodes with a double thickness of dielectric barrier material, such as STOPAQ Coat Wrap CZH (AMCORR, 10624 Sentinel Drive, San Antonio, TX 78217); or equal, to a width of approximately 3 to 4 inches.
5. Ropes attached to tank sidewalls using steel rope anchor shown in figure 48.
6. Individual anode cables run to junction box.
7. Anodes are not connected to structures at test stations or junction boxes at time of installation.
8. Calibrated 0.01 ohm shunts supplied within the junction box for each individual anode.
9. Variable resistors supplied with the junction box for each individual anode when required.

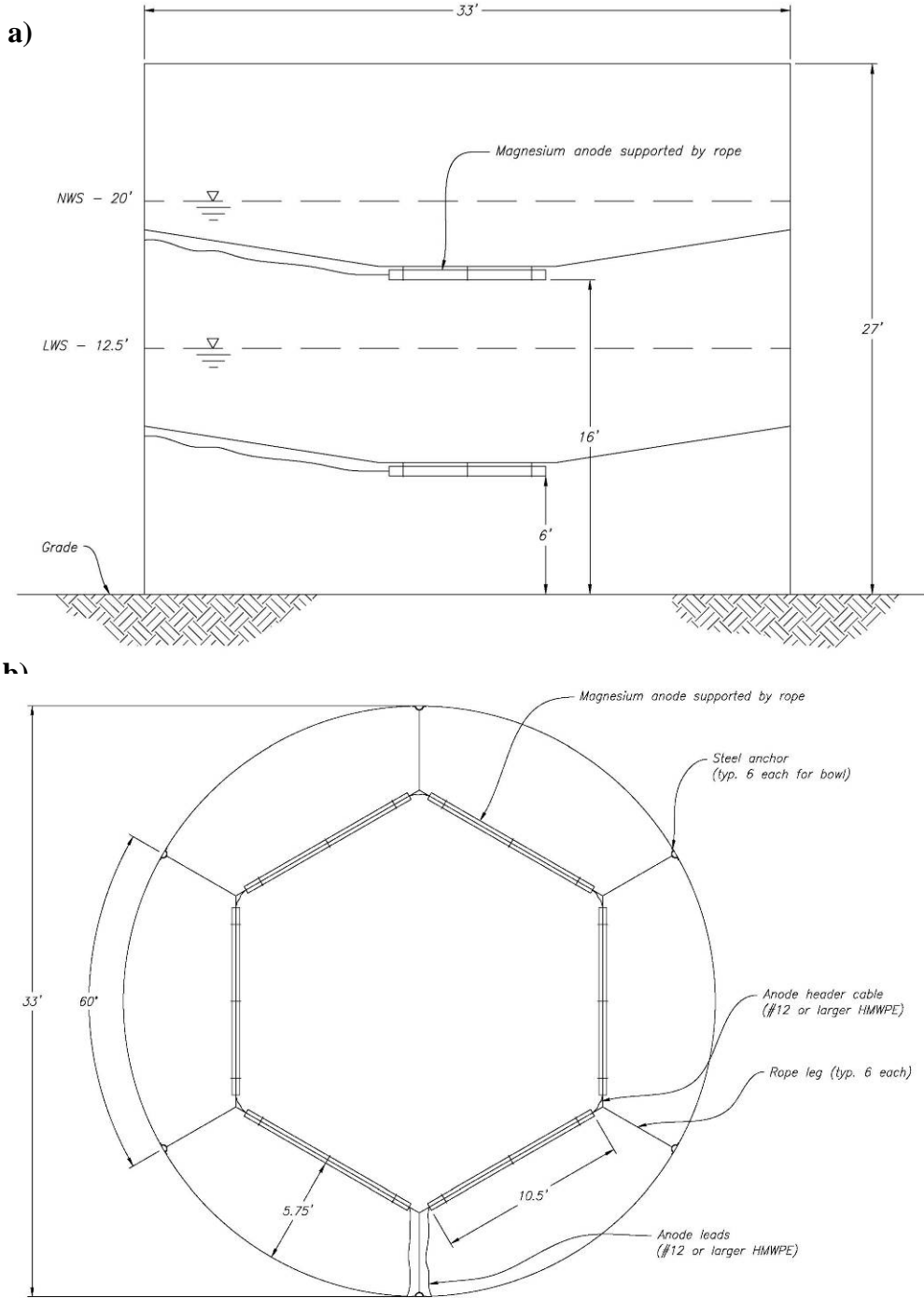

Figure 46. Example schematic of horizontally installed galvanic anodes in a ground tank: (a) elevation view, and (b) plan view.

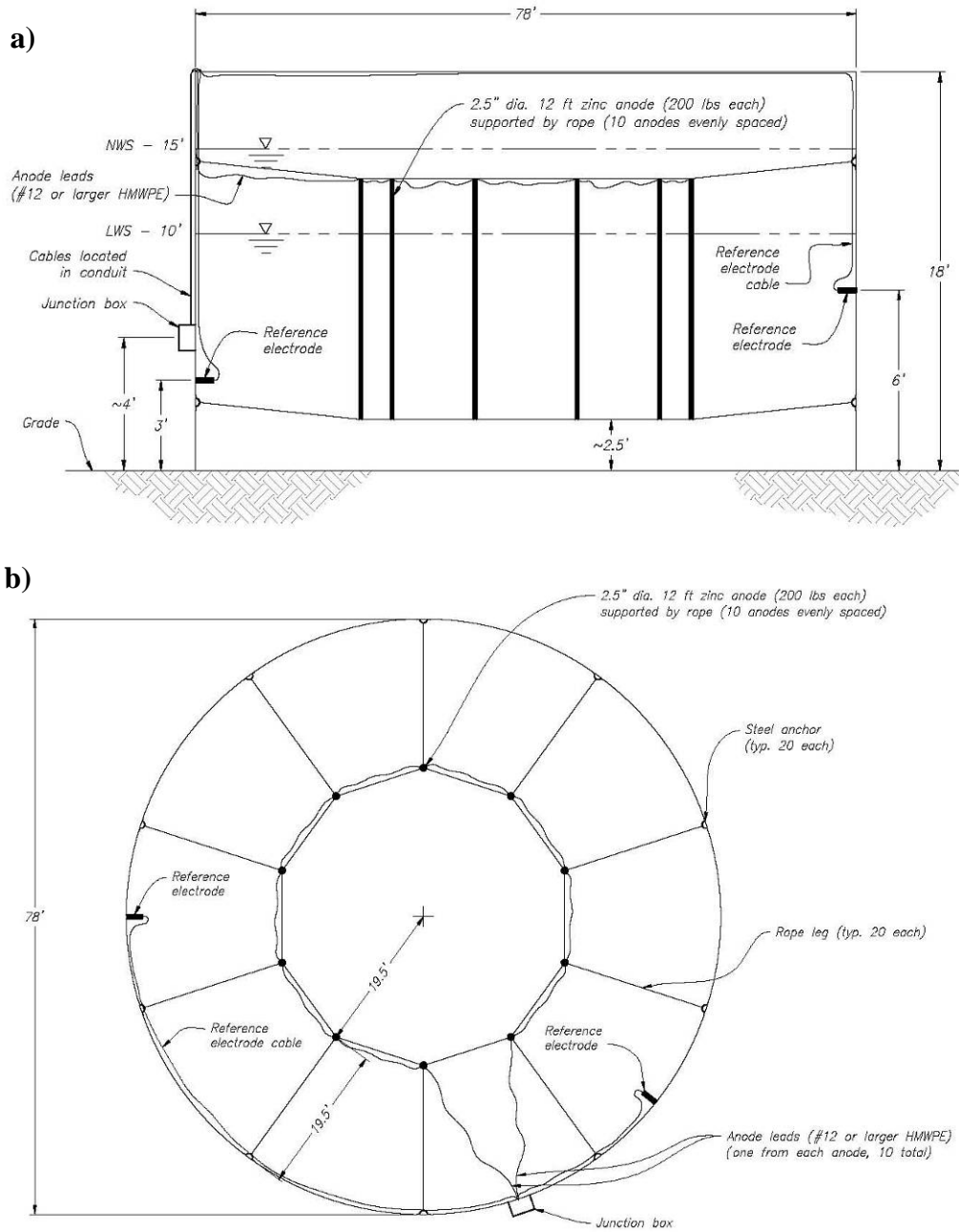

Figure 47. Example schematic of vertically installed galvanic anodes in a ground tank: (a) elevation view, and (b) plan view.

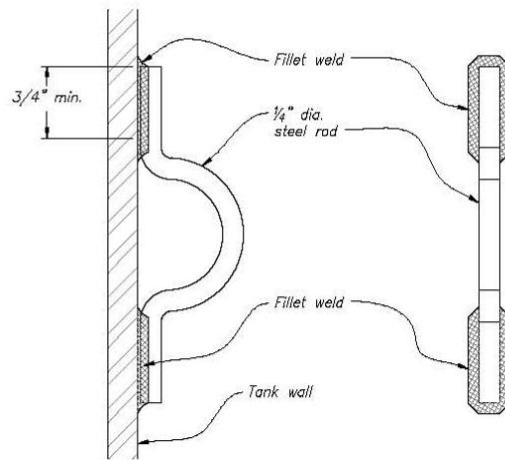

Figure 48. Steel anchor for supporting ropes attached to suspended galvanic anodes such as found in a storage tank.

Surface Mounted

1. For specific anode installation locations, refer to project specification.
2. Anodes installed vertically or horizontally in PVC conduit:
 - a. Installed in PVC conduit as shown in figure 14 so that cutouts, slots, or perforations are oriented away from wall.
 - b. Secure the conduit to the wall at the top, middle, and bottom with stainless steel anchors.
 - c. Thick dielectric barrier, such as STOPAQ CZH or equal, required on structure surface behind magnesium anodes closer than 6 inches to the structure or wall:
 - i. Not required for zinc anodes.
 - d. Individual anode cables run to junction box.
 - e. Anodes are not connected to structures at test stations or junction boxes at time of installation.
 - f. Calibrated 0.01 ohm shunts supplied within the junction box for each individual anode.
 - g. Variable resistors supplied within the junction box for each individual anode when required.

3. Anodes directly mounted to structure:
 - a. Thick dielectric barrier, such as STOPAQ CZH or equal, required on structure surface behind magnesium anodes.
 - i. Not required for zinc anodes.

Impressed Current Systems

Rectifiers

1. Rectifiers are electrical equipment; therefore, they need to be treated with respect. Only a licensed electrician should run power to a rectifier.
2. Rectifier mounted on a wooden pole (as shown in figure 45), metal pole or bracket stand embedded in concrete deck, or wall and located as directed by COR.
3. The rectifier and field circuit breaker installed in accordance with governing electrical codes to include sufficient grounding.
4. Cables labeled in accordance with cable identification requirements.
5. Rectifier grounded on the AC side in accordance with local electrical codes.
6. Do not attach main anode cable or structure cable to the rectifier or energize the rectifier. Energize the system only at time of testing.

Anode Junction Boxes

1. Mounted directly under the rectifier.
2. All anode cables terminate in junction box.
3. Each individual anode connected through individual calibrated shunts as shown in figure 49a.
4. Each individual anode connected through individual variable resistors, if required, as shown in figure 49b.
5. Single cable from anode bus bar and single cable from structure installed for connection from junction box to rectifier terminals.
6. Cables labeled in accordance with cable identification requirements.

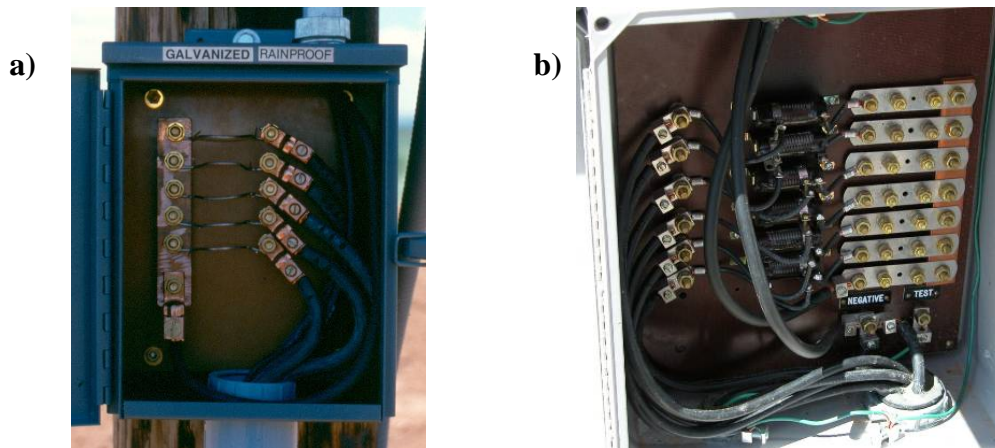

Figure 49. Anode junction boxes for impressed current CP systems: (a) installation with shunts only, and (b) installation with shunts and variable resistors.

Buried

Shallow Bed

Shallow anode bed installation details are as follows herein:

1. Refer to specification for number of anodes, anode spacing, number of anode beds, length of beds, depth of beds, and location of beds.
2. Visually inspect the anodes and anode lead cables:
 - a. Reject all anodes with cracks, entrapped air bubbles, inclusions, or other defects.
 - b. Reject all anodes with damaged insulation or wire, abrasion damage, splices, and/or any form of wire repair.
 - c. Defective anodes should be removed from the worksite no later than the conclusion of the workday.
 - d. No anodes should be buried until the COR has inspected the placement of the anodes and given permission to backfill.
3. Install vertically or horizontally and as directed by the COR.
4. Anodes should be centered in the anode bed and surrounded with carbonaceous backfill.
5. At no time should the anodes be supported by their cables.
6. Anode cables should be installed in accordance with cable section without splices from anode to anode junction box.

Deepwell Bed

Figure 50 shows installation of the above grade portion of a deep well impressed current system showing the rectifier, anode junction box, external circuit breaker, and vent pipe. Anode bed installation details are shown in figure 51 and as follows:

1. Soil resistivity logged every 25 feet to ensure suitability for anode bed site.
2. Refer to specification for number of anodes, anode spacing, number of anode beds, length of beds, depth of beds, and location of beds.
3. Visually inspect the anodes and anode lead cables:
 - a. Reject all anodes with cracks, entrapped air bubbles, inclusions, or other defects.
 - b. Reject all anodes with damaged insulation or wire, abrasion damage, splices, and/or any form of wire repair.
 - c. Defective anodes should be removed from the worksite no later than the conclusion of the workday.
 - d. Inspect insulation on the anode lead wire for damage as the anode is lowered into place.
 - e. If an anode must be retrieved after it has been lowered into the hole, inspect the entire length of the anode lead wire.
4. A nonmetallic vent pipe, as shown in figure 51, installed from the bottom of the bed to the rectifier, if rectifier is near bed location:
 - a. Vent pipe buried except at termination location.
 - b. Terminated above ground, protected, goose necked, and fitted with a perforated cap.
 - c. Goose necked portion installed so it can be removed.
 - d. Vent pipe should be slotted within the coke backfill column and nonslotted outside the limits of the coke backfill column.
 - e. Terminate the vent pipe close to, but not directly beneath, the rectifier.
 - f. Cap the bottom of the vent pipe.

- g. Top of the vent pipe temporarily capped throughout the anode and coke backfill installation procedure to prevent intrusion of foreign material.
5. Anode and vent pipe installation:
- a. Attach the first anode to a centralizer (like the one shown in figure 52a) at both ends using a stainless steel, hose type clamp.
 - b. The vent pipe should be installed with the first anode by attaching it to one of the centralizer straps with a stainless clamp as shown in figure 52b.
 - i. The vent pipe should not be attached to the anode proper.
 - ii. COR will approve the attachment before the vent pipe is lowered into the hole.
 - c. The anode vent pipe/anode/centralizer assembly is lowered into the hole the appropriate distance until the next anode and centralizer distance is reached. Joints are made up as the assembly is lowered into the hole.
 - d. Anodes lowered into the drill hole using rope; at no time should the anodes be supported by their cables.
 - e. Label the anode wires with colored tape or paint to mark the intended final depth.
6. Anode cables installed in PVC conduit from the sand backfill to the anode junction box.
7. No anodes should be buried until the COR has inspected the placement of the anodes and given permission to backfill.
8. Coke backfill material should be introduced into the bottom of the drill hole using a pipe that is the length of the anode hole and a pumping action to fill the drill hole.
- a. Refer to project specification for the length of coke backfill column.
 - b. Do not use the vent pipe to pump the coke.
 - c. 24-hour mandatory waiting period: A full 24-hour waiting period must be allowed for coke settlement and its natural compaction process.

- i. If more coke is needed to bring it up to the depth indicated, a calculated amount of coke is poured into the hole.
 - ii. If more than 20 feet of coke is required to be added, an additional 24-hour waiting period must be allowed and the preceding process repeated.
- d. Anode-to-structure resistance using a four-pin resistance method:
- i. Do not perform over cables or anodes.
 - ii. Determined for each individual anode immediately after coke backfill placement, and after the coke backfill settlement period.
9. Five feet (minimum) of sand backfill placed on top of the coke backfill.
10. Remainder of the drill hole should be backfilled with smooth (no rough edges) pea gravel and introduced into the well bore in a manner that will prevent damage to the anode cables.



Figure 50. Installed impressed current system showing rectifier, anode junction box, external circuit breaker switch, and vent pipe.

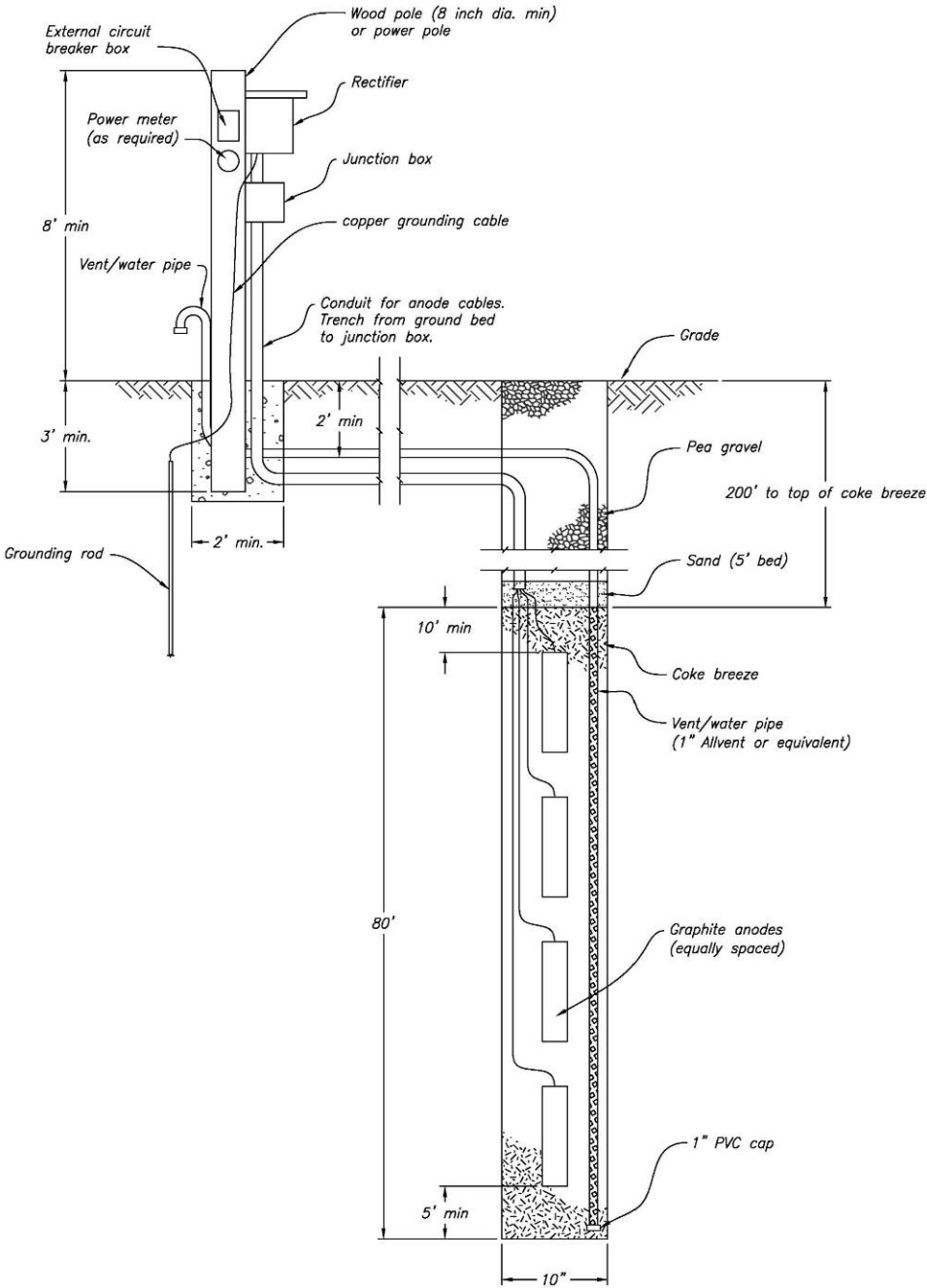

Figure 51. Schematic of example deep well anode bed installation.

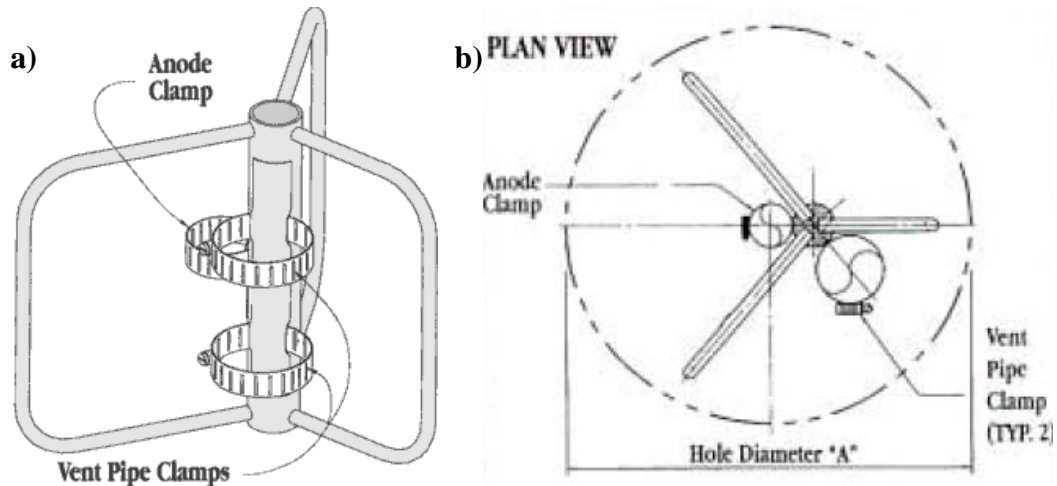

Figure 52. (a) Example of an anode centralizer for deep well anodes, and (b) with anode and vent pipe attached for installation.

Submerged

Wire Anodes

Anode mounting and assembly in accordance with following:

1. Mounted inside perforated nonmetallic anode protector pipes mounted to the sump structure walls as shown in figure 53a and b.
2. Protector pipe attached to wall using plastic ties (figure 53b) or hose clamps, or stainless steel anchors.
3. The half of the anode protector pipe adjacent to the sump wall should not be perforated (figure 53b).
4. Dielectric coating applied to the structure wall behind and adjacent to the anodes so that the dielectric coating extends a minimum of 1-1/2 feet on all sides of the anode protector pipe (figure 53).
5. Cables in accordance with cable sections and protected by PVC or galvanized pipe conduit above the water line between anode and anode junction box.

a)



b)

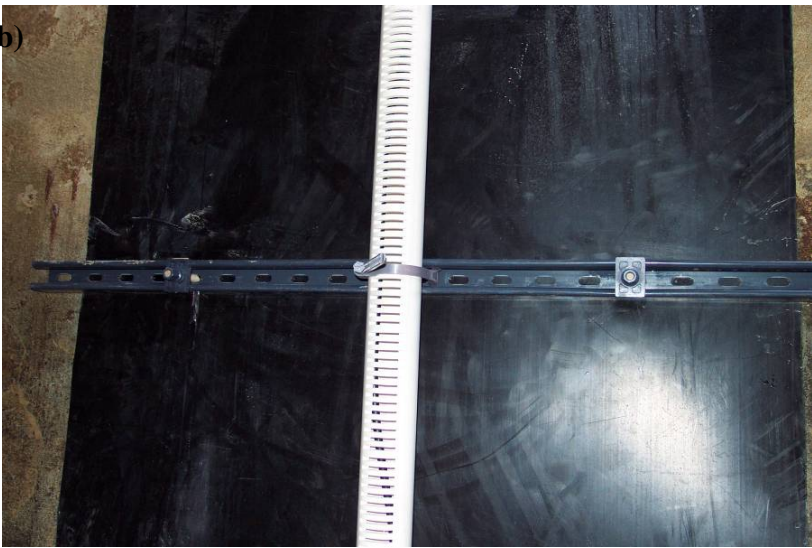

Figure 53. (a) Slotted pipe mounted on sump wall for wire anode installation, and (b) close-up of the slots in the pipe and the wall attachment details. The black sheet is a dielectric material to shield the reinforcement steel in the concrete from the impressed current.

Flush Mounted

Anode mounting and assembly in accordance with figure 54 and described as follows:

1. Hole drilled in structure (e.g., gate skinplate) for the disk anode.
2. Portion of structure surface that will contact the fiber reinforced polymer (FRP) anode shield should be cleaned without damaging the coating.
3. Back surface (side placed against structure) of the FRP anode shield roughened and cleaned.
4. Polyurethane sealer applied to the back surface of the FRP anode shield:
 - a. A continuous bead formed approximately 1 inch from the outside edge of the FRP anode shield and approximately 1 inch from the FRP mounting stud.
 - b. Between these two beads, continuous beads applied in a crosshatch pattern at approximately 2-inch centers.
5. Anode stud inserted into drilled hole from the upstream or water side and fastened using the FRP washer and nut on the downstream or dry side.
 - a. Dry side refers to either atmospheric only or soil.
6. Tighten the nut to the torque recommended by the disk anode manufacturer.
7. Displaced polyurethane sealer smoothed between the periphery of the anode shield and structure, and any excess polyurethane sealer removed.
8. Compression fitting, junction box, nuts, and washers on the titanium anode shaft installed.
9. The COR should approve the routing of the installed conduit system and location of the installed junction boxes prior to installation.

Figure 55 shows a finished disk anode assembly. The red arrow in figure 55a shows the anode on the upstream side of the gate. Figure 55b shows the downstream side (dry side) of the disk anode assembly.

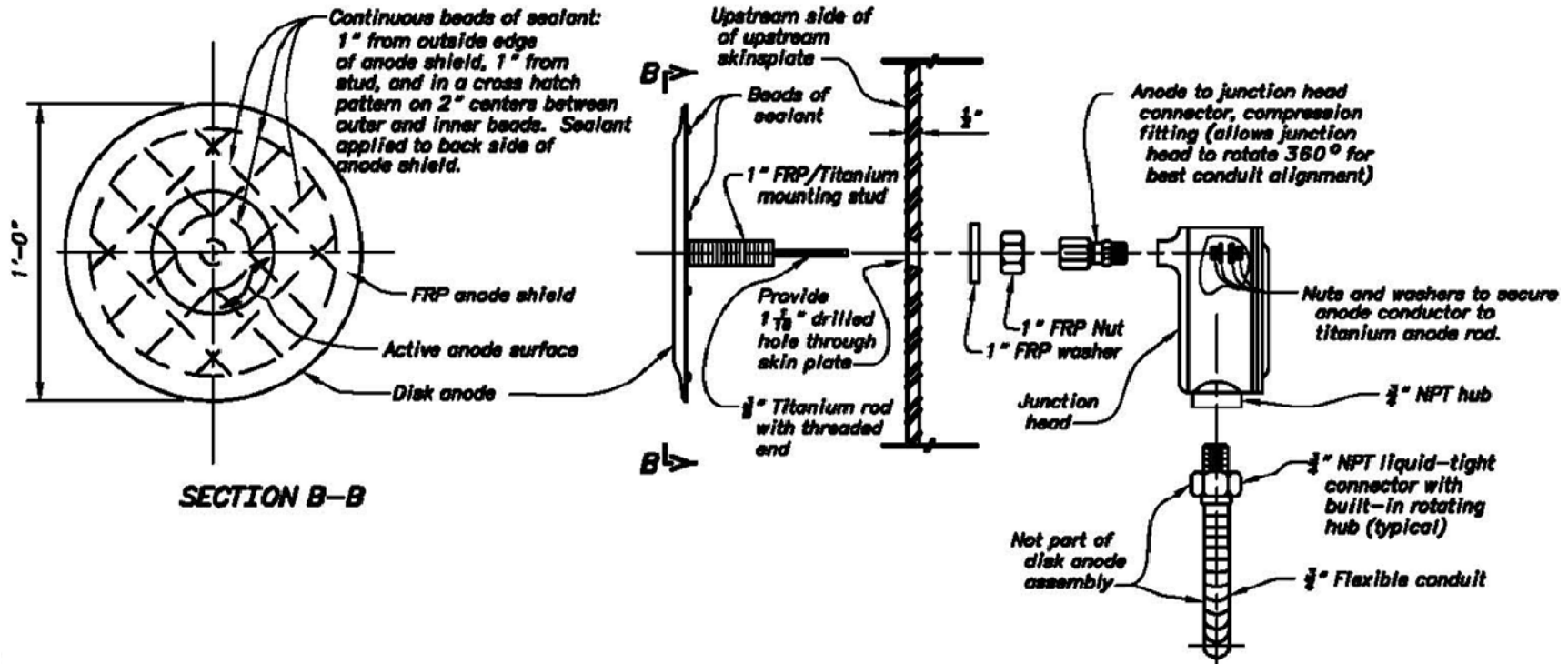

Figure 54. Schematic of flush-mounted, disk mixed metal oxide anode showing front view (left side) and profile assembly.

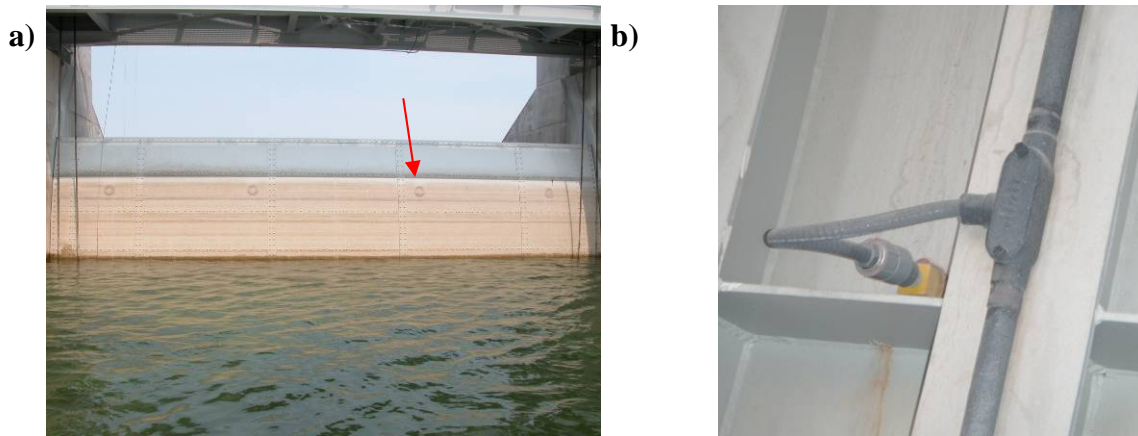

Figure 55. Flush mounted impressed current disk anodes: (a) arrow indicates the location of a disk anode on the upstream side of a radial gate; (b) downstream side of the gate showing the finished anode installation.

Permanent Reference Electrodes

Buried

Permanent reference electrodes are buried in accordance with manufacturer's instructions and as follows:

1. See specification for permanent reference electrode location.
2. Bagged electrode removed from plastic shipping bag or carton.
3. Record the serial number and quality control test potential; these are located on the yellow tag attached to the lead wire.
4. Calibration testing:
 - a. Option 1: Prior to installation, the prepackaged reference electrode is soaked in a container of potable water for 30 minutes:
 - i. Measure potential difference between the permanent reference electrode and an independent (portable) calibrated reference electrode placed in the water adjacent to the permanent reference electrode.
 - ii. Permanent reference electrodes not within a 10- to 15-mV potential difference should be removed and replaced at the contractor's expense.
 - b. Option 2: Electrode placed into borehole or excavation oriented vertically or horizontally.

- i. Sift fine backfill into the borehole. Fill to about 2 inches (5 centimeters) above top of bag.
 - ii. For excavation, pile the soil to form a berm around the electrode. The berm should be approximately 6 inches (15 centimeters) higher than the top of the bag and completely surround it.
 - iii. Saturate the bag by slowly pouring approximately 5 gallons (20 liters) of water onto the bag.
 - iv. Measure potential difference between the permanent reference electrode and an independent (portable) calibrated reference electrode placed as close as possible to the bag of the permanent reference.
 - v. Permanent reference electrodes not within a 10- to 15-mV potential difference should be removed and replaced at the contractor's expense.
5. Fill the hole or excavation with normal backfill only after permanent reference electrodes have been tested and approved by COR.
 6. Do not lift the electrode by pulling the lead wire.
 7. Do not allow to freeze, install below frost line, and keep dry prior to installation.
 8. Reference electrode lead wire and pipe test lead wire should be connected to separate terminals in test station.

Submerged

Through-Wall

Permanent reference electrodes are installed in accordance with manufacturer's instructions and as follows:

1. Electrode installed through threaded port in wall of structure.
2. Locate electrode below minimum water elevation.
3. Electrode cable run through separate galvanized conduit from the anode cables to the junction box.
4. Electrode cable terminated in junction box.

Surface Mounted

Permanent reference electrodes are installed in accordance with manufacturer's instructions and as follows:

1. Electrode installed inside structure, securely attaching to the wall, so that it is removable without damaging the electrode.
2. Electrode cable protected from damage inside structure.
3. Electrode cable run through separate galvanized conduit from the anode cables to the junction box.
4. Electrode cable terminated in junction box.

Chapter IV

Startup and Testing

Procedures

1. Includes energizing, adjusting, and testing the CP systems.
2. Performed in the presence of COR.
3. COR informed of the date, time, and tests to be performed at least 5 working days prior to testing.

Safety

Safety issues involved with CP systems include, but are not limited to:

1. Environmental issues including heat, cold, rain, and lightening:
 - a. Do not test electrical equipment when it is raining.
2. Insects and other pests including snakes, wasps, and spiders:
 - a. Watch where you step.
 - b. Open junction boxes, test stations, and rectifiers with care.
3. Rectifiers have safety concerns from both AC and DC voltages:
 - a. Approach a rectifier carefully.
 - b. Check for grounding using an AC voltmeter or AC voltage proximity detector:
 - i. Do not grab the latch or handle on the rectifier without checking for an AC short. If necessary, touch the cabinet with the back of your hand. If the casing is shorted and you touch it with the back of your hand, you can remove your hand. However, if you grab it and your hand closes, you cannot let go potentially resulting in serious injury.
 - c. All work performed on the rectifier should take place with the power off at both the rectifier and an external circuit breaker.
 - d. If possible, only work with one hand in the rectifier cabinet at a time to avoid creating a circuit through your body.

- e. Table 1 shows the physiological effects of 60-hertz AC.
- 4. Shock hazards and shorting are possible within the impressed current anode junction boxes if the box is too small for easy access to all the cables and resistors.

Table 1. Physiological Effects of 60-Hertz AC

Current (mA)	Physiological Effect
< 1	No sensation
1 to 8	Threshold of perception (no pain)
8 to 15	Painful (no loss of muscular control)
15 to 20	Painful (cannot let go)
20 to 50	Painful (breathing difficulties)
50 to 100	Ventricular fibrillation possible
100 to 200	Fibrillation certain (defibrillation needed)
> 200	Severe burns

Test Equipment

- 1. Portable voltmeter:
 - a. High impedance digital multimeter: Fluke Model 27 (figure 56a), manufactured by Fluke Corporation, 6920 Seaway Boulevard, Everett, WA 98203; or equal, having the following essential characteristics:
 - i. Minimum input impedance of 10 megohms.
 - ii. Capable of measuring DC voltages between ± 0.1 mV to $\pm 1,000$ volts.
 - b. Selectable input resistance digital multimeter: MCM LC-4 (figure 56b), manufactured by M.C. Miller Co., Inc., 11640 U.S. Highway 1, Sebastian, FL 32958; or equal, having the following essential characteristics:
 - i. Selectable input resistance 0-200 ohms (0.1-ohm resolution).
 - ii. Selectable DC voltage range 0-200 volts (0.01-mV resolution).

2. Portable copper/copper sulfate (Cu/CuSO_4) reference electrode as shown in figure 57.
3. Meter for determining resistivity of soil around anode (figure 58).

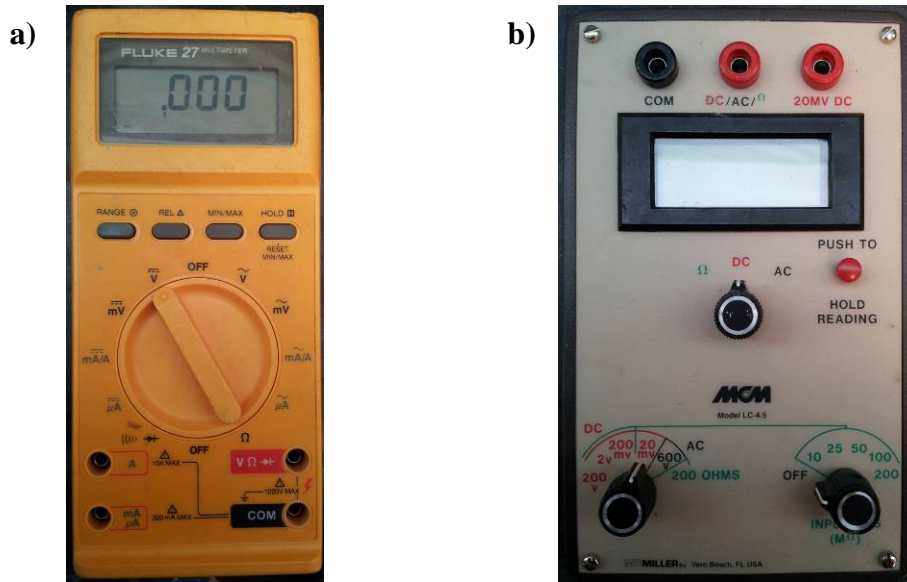

Figure 56. Multimeters for measuring potentials associated with CP systems: (a) Fluke 27 digital multimeter, and (b) MC Miller LC-4 variable resistance input digital multimeter.

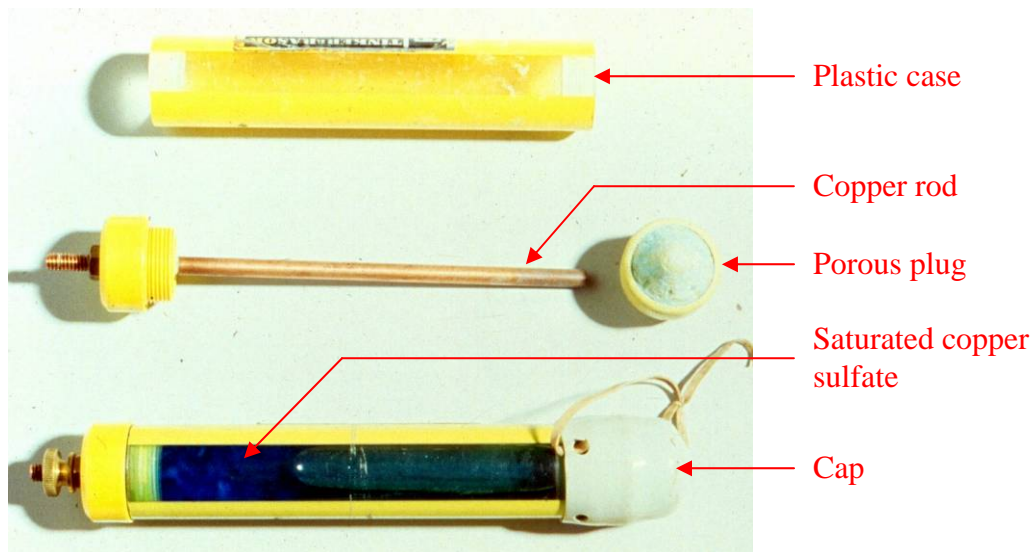

Figure 57. Copper/copper sulfate portable reference electrode for determining structure-to-electrolyte and anode-to-electrolyte potentials. The various components of the electrode are labeled to include plastic case, copper rod, porous plug, saturated copper sulfate, and cap.



Figure 58. Meter for determining resistivity of soil around anodes.

Testing

Pre-energizing

1. Structure electrical continuity.
2. Test station integrity:
 - a. Voltage difference between the cables.
3. Static anode-to-electrolyte potentials:
 - a. At anode location for impressed current system.
 - b. At each test station enclosure for galvanic anodes.
4. Static structure-to-soil potentials of the buried metalwork:
 - a. At each individual test station location.
 - b. Portable reference electrode placed as close to the buried metalwork as possible.
5. Static structure-to-water potentials of the submerged metalwork:
 - a. At each individual structure location.
 - b. Portable submersible reference electrode placed as close to the submerged metalwork as possible.

Energizing and Testing Systems

First Test Cycle

Galvanic Anode Systems

1. Anode cables connected through individual shunt and variable resistors (if necessary) to No. 6 AWG or larger structure cable in test station or junction box.
2. Protective (uncorrected) and polarized structure-to-electrolyte potentials:
 - a. Buried:
 - i. At each individual test station location.
 - ii. Portable reference electrode placed as close to the buried metalwork as possible.
 - b. Submerged:
 - i. At each individual structure location.
 - ii. Portable submersible reference electrode placed as close to the submerged metalwork as possible.
3. Current output of each individual anode in junction box.
4. Variable resistor setting for each anode and structure.

Impressed Current Systems

1. Cable connection to rectifier:
 - a. Structure cable must be connected to the **NEGATIVE DC** output terminal.
 - b. Anode cable must be connected to the **POSITIVE DC** output terminal.
2. Protective (uncorrected) and polarized structure-to-electrolyte potentials:
 - a. Buried:
 - i. At each individual test station location.
 - ii. Portable reference electrode placed as close to the buried metalwork as possible.

- b. Submerged:
 - i. At each individual structure location.
 - ii. Portable submersible reference electrode placed as close to the submerged metalwork as possible.
- 3. Current output of each individual anode in junction box.
- 4. Variable resistor setting for each anode and structure.
- 5. Rectifier outputs in volts and amperes and associated tap settings.

Second and Subsequent Testing Cycles

- 1. Time between testing cycles is 30 to 60 days.
- 2. Cathodic protection system not adjusted between testing cycles.
- 3. All testing during the first testing cycle repeated.
- 4. If testing cycle data indicates that the CP system requires adjustment to meet specifications requirements, CP system adjusted and subsequent testing cycle conducted within a 30- to 60-day window.

Appendix

Galvanic CP System Checklist

Item (required)	
	anodes
	cables - anode (galvanic)
	cables - structure (pipe)
	cables - test
	cables - bond
	exothermic weld supplies
	joint bond supplies
	test station
	"CP" warning tape
Item (system dependent)	
	junction box
	permanent reference electrode
	permanent reference electrode cable
	cable - foreign structure - bond
	cable - foreign structure - test
	cable - casing structure - bond
	cable - casing structure - test
Item (misc)	
	test station barrier
	concrete for test station

Impressed Current CP System Checklist

Item (required)	
	rectifier
	junction box
	circuit breaker box
	anodes
	vent pipe, caps, u-joint
	coke backfill
	cables - anode (IC)
	cables - structure (pipe)
	cables - test
	cables - bond
	grounding rod and cable
	exothermic weld supplies
	joint bond supplies
	test station
	"CP" warning tape
Item (system dependent)	
	permanent reference electrode
	permanent reference electrode cable
	cable - foreign structure - bond
	cable - foreign structure - test
	cable - casing structure - bond
	cable - casing structure - test
Item (misc)	
	sand & pea gravel backfill
	conduit for anode cables
	test station barrier
	concrete for test station & rectifier post